



Mikuni American Corporation
8910 Mikuni Avenue
Northridge, CA 91324-3496
www.mikuni.com

HSR Carburetor
Easy Kits

Installation Instructions

For

Twin Cam/Evo Kit: # 42-18
w/o cover

Evo Big Twin Kit: # 42-7
Evo 1990 - 1999

Easy Kit Installation Instructions

The HSR series carburetors are precise yet durable instruments; however, like any other piece of fine equipment, they require correct installation and reasonable care to assure optimum performance and long life. Extra time spent during installation will pay off in both short and long term performance and reliability.

This Mikuni HSR carburetor kit is designed to be a bolt-on application, and as such, is set-up and jetted properly for most applications. However, since many Harley-Davidson motors are often highly modified, alternate tuning settings may be required. The Mikuni HSR Tuning Manual helps make jetting alterations and adjustments an easy matter.

NOTE: Carburetor Kits not designated as C.A.R.B. exempt, are not legal for motor vehicles operated on public highways in the state of California, or in any other states and countries where similar laws apply.

Notes, Cautions and Warnings

Statements in this manual preceded by these words are very important:

NOTE:

Gives helpful information that can make a job easier.

CAUTION

Indicates a possibility of damage to the vehicle if instructions are not followed.

WARNING

Indicates a possibility of personal injury or vehicle damage if instructions are not followed.

WARNING

Read these instructions carefully before you begin installation of your HSR kit. All procedures in this manual should be followed, paying particular attention to the following:

1. Mikuni HSR series carburetors require the use of a push/pull throttle assembly to assure closing of the throttle valve.
2. The throttle cables should be routed freely (without sharp bends) between the throttle twist grip and the carburetor and must not be pinched.
3. Gasoline is extremely flammable and is explosive under certain conditions. Do not install your Mikuni near open flame.
4. Never look directly into the bore of the carburetor while the engine is running as injury may result from possible backfire.

CAUTION

A moderate level of mechanical skill is required to install this carburetor kit. After reading these instructions, if you have any doubts, we recommend that you have a professional install it for you. If you install the kit yourself, we recommend that you also use the applicable shop manual for your motorcycle.

Disassembly

1. Disconnect the negative (-) battery terminal.
2. Turn the fuel petcock to the "OFF" position.
3. Elevate the rear of the fuel tank for better access. It is not necessary to remove the tank to install this kit.
4. Remove the complete air cleaner assembly.
5. Disconnect the choke cable from its bracket.
6. Disconnect the vacuum and fuel hoses from the carb.
7. Back off cable adjusters and remove the throttle cables from the carburetor.
8. Remove the carburetor from the motorcycle.
9. Remove enrichener (choke) cable from the carburetor.

Installation

1. Throttle Cables

WARNING

Control cables must not pull tight when handlebars are turned to the left and right fork stops. Also, be sure control cables and wires are clear of the fork stops at the steering head so that they will not be pinched when forks are turned against stops.

- A. The HSR carburetor uses the stock throttle cables. However, new cable routing is required to prevent cable binding. To re-route the cables you must elevate the rear of the tank. Cut the stock cable tie from the frame, located above the front cylinder. Some models may use sheet metal clips; if so, remove the cables from the clip. Re-route the cables under the frame (Figure 1).

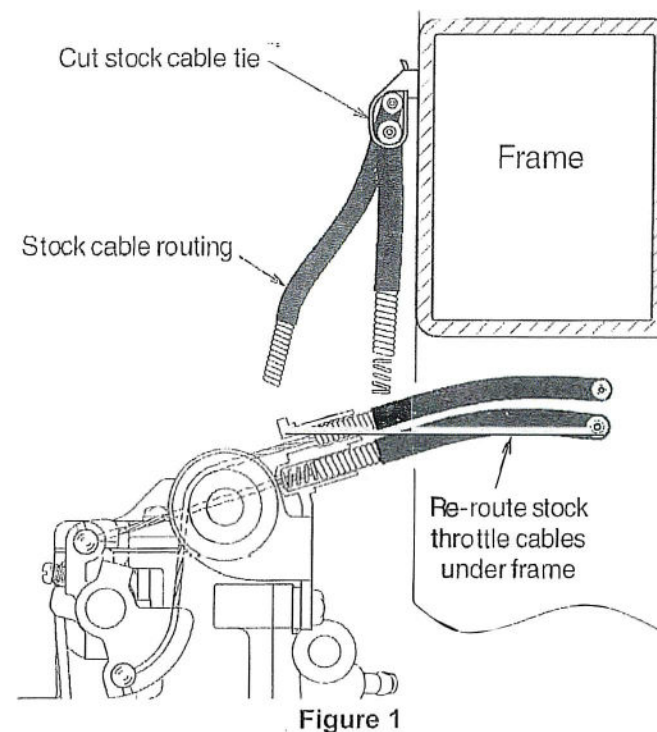
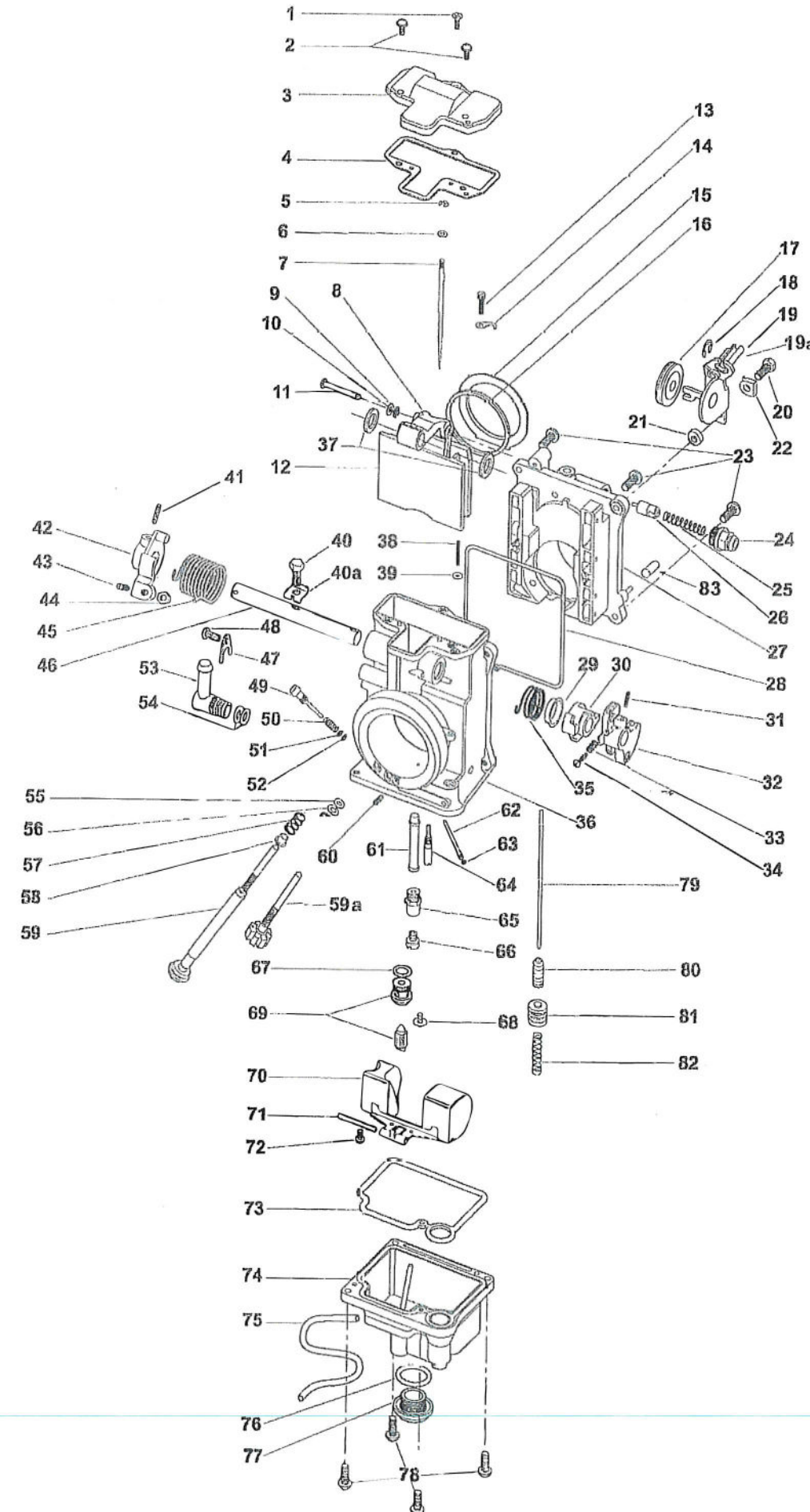

Figure 1



6. Cable Lube

Remove upper throttle housing and inject cable lube in each cable (Figure 6).

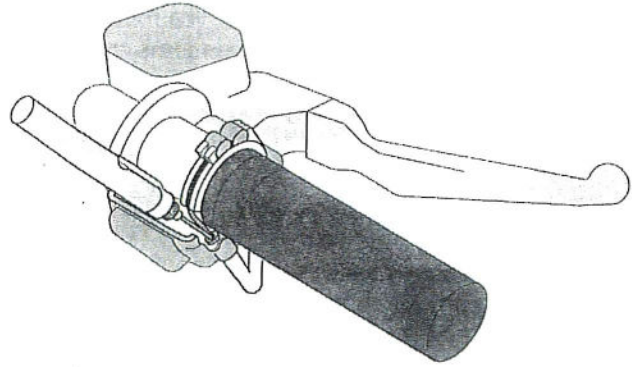

Figure 6

7. Hose Routing

Route the carburetor overflow hose behind the rear push rod tubes and between the crankcase and transmission. Do not connect to any other hose.

NOTE:

1. If you are not using the V.O.E.S., seal the Vacuum Fitting on the carburetor.
2. The Vent Fitting located above the Fuel Fitting *must not* be sealed! Sealing it results in erratic air/fuel mixture ratios, poor performance and possible engine damage.
3. You may have some remaining hoses. Since this is a performance application only, any remaining hoses and related hardware can be removed, as they are not required.

8. Choke Cable Installation

HSR series carburetors use either of two choke cables: the stock Harley-Davidson cable (1990 and later) or the Mikuni cable. The Mikuni cable is furnished for installations that do not have a Harley Choke cable.

Follow these steps to install the choke cable:

1. Remove the stock Harley choke cable assembly.
2. Remove the spring and plunger from the stock cable.
3. Remove the Mikuni "Starter Nut" from the HSR.
4. Remove the Mikuni spring and plunger from the HSR.
5. Install the Mikuni spring and plunger on the Harley cable.
6. Install the Harley choke cable with the fitted Mikuni spring and plunger into the HSR carburetor. DO NOT use the Mikuni Starter Nut; discard it. DO NOT use the Harley spring or plunger; discard them. Note: If you do not have installation instructions, you may download them from the "www.mikuni.com" website in the "manuals" section.

If the Mikuni Starter Nut is fitted to the Harley cable, the choke plunger is held off its seat and the choke is open all the time. If the Harley spring and plunger are used, the plunger does not seal and the choke is open all the time. The result, in both cases, is very poor fuel mileage (30 mpg or less).

Another possible cause of poor mileage, rough idle and fouled spark plugs is incorrect cable routing. The stock Harley choke cable is very stiff and may not be fully seated in the metal elbow at the carburetor end.

EK-3

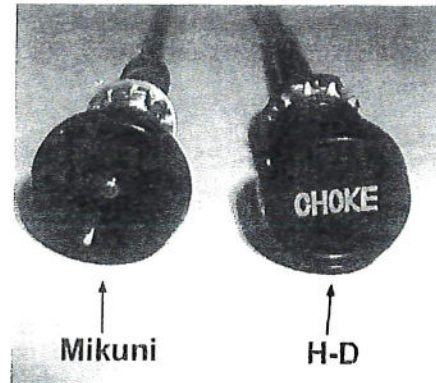

Harley's choke knob has the word "CHOKE" in white. The Mikuni knob has a small brass bump in its center.

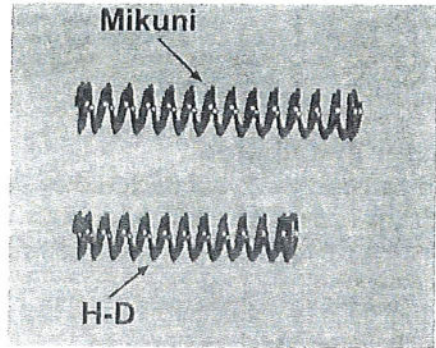

The Mikuni spring is longer and stiffer than Harley's.

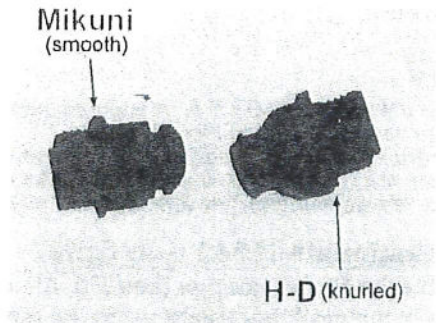

The Mikuni nut has a smaller hole where the cable fits and must not be used with the Harley choke cable.

The Harley nut is larger and is serrated around its edge.

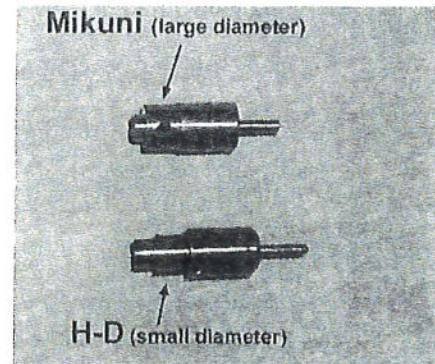

The Mikuni "Starter Plunger" and the Harley plunger are different and must not be interchanged. While they are very similar and both slide into the HSR carburetor, the Harley plunger does not work in the HSR. The Harley plunger does not seal and causes a severe rich condition.

EK-4

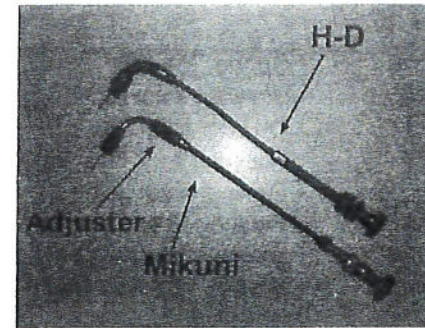

The Mikuni choke cable has an adjuster; the Harley cable does not. The Mikuni threaded section is steel; Harley's is plastic. The Mikuni cable has a hold-open detent; Harley's has a friction adjuster. The Mikuni knob has a small brass center while Harley's has the word "CHOKE" in white.

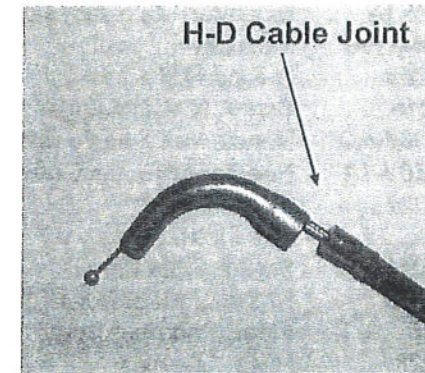

The Harley cable end may not completely bottom in the socket formed in the metal elbow. If the cable is not bottomed, the starter plunger does not seal. Poor mileage and a rich idle results.

The fix is to re-route the cable so that it can bottom. A simple 'wiggle' may be enough to get the cable seated.

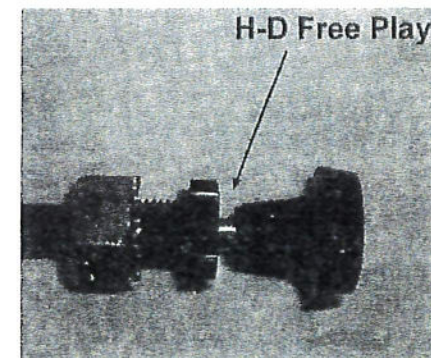

There must be some free play in the choke cable to ensure that the choke plunger is bottoming (sealing). Any amount of free play is okay, but there must be some.

H-D: Check free play by slightly loosening the friction nut. Then, slide the knob in and out to check free play.

Mikuni: If there is no free play, use the adjuster under the rubber boot near the carburetor.

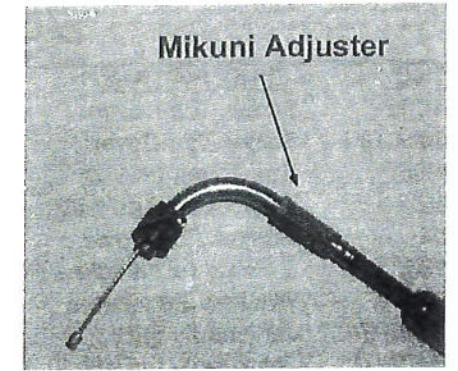

Mikuni's cable adjuster is covered by a rubber boot. There must be some free play in the cable. Any amount will do but there must be some to ensure that the choke plunger is fully bottomed.

9. Starting

- A. Re-connect the battery at this time and re-assemble the remainder of the motorcycle.
- B. Turn the fuel petcock on and start the motorcycle as you normally would.
- C. After the engine is warmed up adjust the idle to the recommended idle speed of 1,000 to 1,100 rpm.

NOTE:

'95 to present models are equipped with a vacuum petcock. It may be necessary to crank the engine over several times before fuel flows to the carburetor.

10. Tuning

See the enclosed "HSR Tuning Manual" for fine-tuning instructions. This manual can also be printed from our website at: www.mikuni.com.

Parts List for 42-7 and 42-18

Part#	Description	Qty	HSR Kit
TM42-6	Carburetor	1	7, 18
HS42/001	Adapter	1	7, 18
HS42/002	Screw, Adapter	3	7
HS42/003	O-ring (Large)	1	7, 18
HS42/006	Cover, Cleaner	1	7
Z70/073	Cable Lube	1	7, 18
N100.604-165	Main Jet	1	7, 18
VM28/486-20	Pilot Jet	1	18
TM42/11-50	Pump Nozzle	1	18
N124.063	O-Ring	1	18
Z70/045	Hose Clamp	1	7, 18
Z70/146	Cable Tie	3	7, 18

Twin Cam Optional Tuning

Suggestion: Certain Twin Cam 88/95 ci configurations may improve mileage by using our #20 pilot jet, #50 a/p nozzle and #2 needle clip position. These parts are now included. Refer to the HSR Tuning Manual (pg. 8-9) for detailed instructions.

HSR PARTS LIST

#	PART NO.	DESCRIPTION
1.	C5=0410-B	Screw, Top Cover
2.	CW2=0414-B	Screw, Top Cover
3.	776-39005	Top Cover, (42/45)
3a.	HS42/081	Top Cover, (HSR 48)
4.	TM42/04	Gasket, Top Cover
5.	BS32/126	E-Ring, Jet Needle
6.	826-03002	Washer, Jet Needle
7.	J8-8DDY01-97	Jet Needle (42)
7a.	J8-8CFY02-97	Jet Needle (45/48)
8.	TM42/03	Lever, T.V. (42/45)
8a.	TM42/08-1A	Lever, T.V. (48)
9.	B401/56	E-Ring, Link Lever
10.	B401/10	Packing, Link Lever
11.	834-23041	Pin, Link Lever
12.	TM42/08-3.0	Throttle Valve (Slide)
13.	739-13002	Screw, Needle Retainer
14.	TM42/16	Clip, Needle Retainer
15.	TM42/13	Sealing Ring, T.V. (42/45)
15a.	TM48/02	Sealing Ring, T.V. (48)
16.	TM42/10	Seal, Throttle Valve
17.	925-98006	Pulley, Cable Bracket
18.	53974	E-Ring, Cable Bracket
19.	TM42/51	Bracket Ass'y, Cable
19a.	TM42/53	Bracket Ass'y, Sportster
20.	B3=0520-B	Bolt, Bracket
21.	VM28/204	Spacer, Bracket
22.	TM42/38	Plate, Lock Tab
23.	C2=0514-B	Screw
24.	640-12001	Starter Nut, Choke
25.	VM14/241	Spring, Starter Plunger
26.	N189.192	Starter Plunger
27.	TM42/06	Body, Bearing & Spigot (42/45)
27a.	TM48/02	Body, Bearing & Spigot (48)
28.	616-94029	Seal, Spigot Body
29.	925-19011	Ring (Steel)
30.	TM42/43	Lever, A/P
31.	N138.019	Pin, Throttle Lever
32.	TM42/48	Lever, Throttle
33.	M12F/46-BB	Spring, A/P
34.	MC-0316-B	Screw, A/P
35.	TM42/47	Spring, A/P
36.	TM42SS1/01-0	Mixing Body (42/45)
36a.	TM48SS1/01	Mixing Body (48)
37.	B36/95	Packing, Shaft (Plastic)
38.	TM42/36	Adjusting Screw, A/P
39.	B30/205	O-Ring, A/P Screw
40.	TM40/89	Bolt
40a.	TM42/17	Plate, Lock Tab for Shaft
41.	BN38/43	Pin, Return Lever
42.	TM42/46	Lever, Return
43.	B30/1069	Adjusting Screw, Throttle
44.	N3=04	Nut, Throttle Stop
45.	TM42/19	Spring, Throttle Return
46.	700-15012	Shaft, Throttle
47.	TM42/15	Plate, Fuel Joint Retainer
48.	C2=0410-B	Screw, Fuel Joint
49.	604-26014	Screw, Pilot Air

50.	N133.206	Spring, Pilot Air
51.	VM12/205	Washer, Pilot Air
52.	N133.037	O-Ring, Pilot Air
53.	TM40/27	Fuel Joint
54.	KV/10	O-Ring, Fuel Joint
55.	B30/398	Packing, Idle Adjuster
56.	VM22/138	Washer, Idle Adjuster
57.	730-09018	Spring, Idle Adjuster
58.	925-15001	Ring, Idle Adjuster
59.	TM42/32	Idle Adjuster (Long)
59a.	990-605-065	Idle Adjuster (Short)
60.	BS30/97-00	Air Jet (Blank)
61.	784-430000-Y-6	Needle Jet (723)
62.	TM42/11-70	Nozzle, Accel. Pump
63.	N124.063	O-Ring, A/P
64.	VM28/486-25	Pilot Jet
65.	TM42/12	Extender, Main Jet (42/45)
65a.	TM42/12-1A	Extender, Main Jet (48)
66.	N100.604-160	Main Jet
67.	616-33003	O-Ring N.V.
68.	VM13/216	Screw, N.V. Retainer
69.	786-27001-4.2	Needle Valve Ass'y (42/45)
69a.	786-27002-1A	Needle Valve Ass'y (48)
70.	859-32027	Float Ass'y
71.	BV26/22	Pin, Float
72.	C2=0410	Screw, Float Pin
73.	616-94028	Packing, Float Bowl
74.	TM42/05	Float, Chamber Body
75.	N122.028	Hose, Overflow
76.	VM28/254	O-Ring, Drain Plug
77.	TM32/41	Drain plug (42/45)
77a.	TM32/41-1D	Drain Plug (48)
78.	C2=0412-B	Screw, Flt Bowl, short
79.	TM36/44-1A	Rod, A/P
80.	TM36/64	Boot, A/P Rod
81.	TM36/60	Plunger, A/P
82.	VM14SC13/89	Spring, A/P
83.	N198.063	Rubber Cap, Purge Port

Alternate Parts

Jet Needles:

HSR42	HSR45/48	
J8-8DDY01-95	J8-8CFY02-95	Richer
J8-8DDY01-96	J8-8CFY02-96	Richer
J8-8DDY01-97	J8-8CFY02-97	Std
J8-8DDY01-98	J8-8CFY02-98	Leaner

Accelerator Pump Nozzles:

TM42/11-70	Std
TM42/11-60	Leaner
TM42/11-50	Leaner

Needle Valve Assemblies:

786-27002-1A-4.5	Std (HSR48)
786-27001-4.2	Std (HSR42/45)
786-27001-3.5	Smaller
786-27001-2.3	Pressure only

Rebuild Kit:

HSR42/45:	KHS-016
HSR48:	KHS-031

NOTE:
 1. Lined through-part numbers are not available.
 2. Parts in bold are included in rebuild kits.

- B. Connect the throttle cables to the carburetor bell crank by first installing the closing cable, then the opening cable (Figure 2).

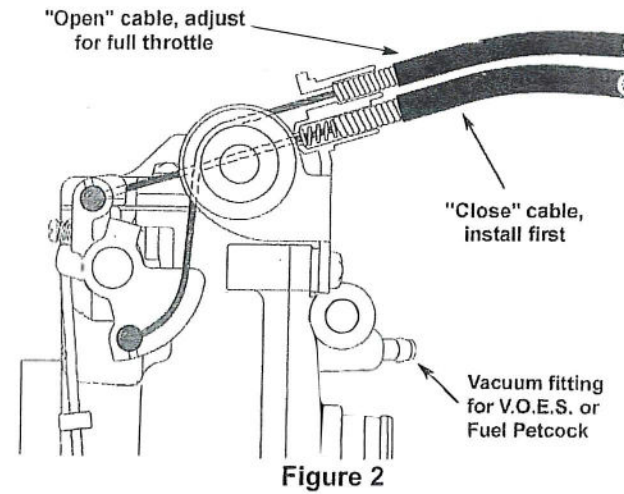

Figure 2

2. Carburetor Installation

- Insert the carburetor into the stock Harley-Davidson manifold. The carburetor will fit very snugly. Use grease as a lubricant. Be sure that the choke routing doesn't become kinked.
- Slip the fuel hose onto the carburetor's fuel nipple and secure with the enclosed hose clamp.
- Some Twin Cam installations may require removal of a small amount of fin material from the cylinders to clear the float bowl.

NOTE:

- If you are not using the V.O. E. S. or vacuum petcock, be sure to cap the vacuum fitting on the carburetor.
- Before installing the carburetor, check the condition of the carburetor seal; if damaged, it should be replaced to prevent air leaks. We recommend that you start with a new seal.

3. Stock Backplate (1340 Evo Only)

- Assemble the Mikuni adapter (see Fig. 4). Attach the adapter to the stock backplate using the provided screws. The stock screws are too long.
- Use a small amount of thread lock on each of the screws (Figure 3).
- Fully seat the carburetor into the manifold and center it between the cylinders. Bolt the backplate to the heads.

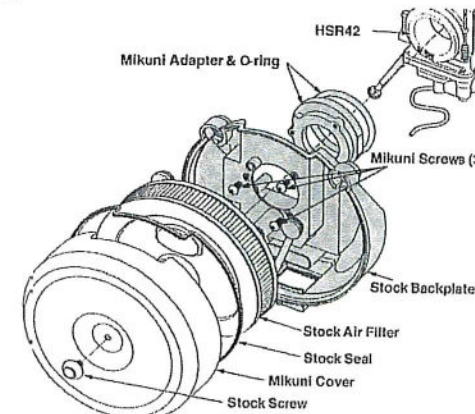

Figure 3

4. Screamin' Eagle Backplate

- Insert the enclosed large O-ring into the Mikuni adapter. Assemble to the Screamin' Eagle backplate. Use thread lock on each of the stock bolts.
- The remainder of the Mikuni/Screamin' Eagle installation follows the Harley instructions. We recommend that you follow those directions to complete the air cleaner installation (Figure 4).

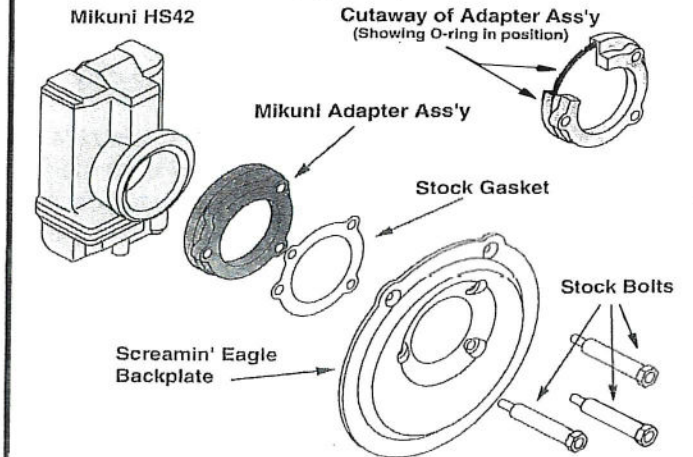

Figure 4

5. Throttle Cable Adjustment

CAUTION

It is important to adjust the cable as described below to ensure that the close cable operates correctly and can close the carburetor fully.

- Rotate the throttle grip to the full open position and check to see that the throttle valve (slide) opens completely by looking into the carburetor bore. If the throttle valve doesn't open fully, unscrew the adjuster on the opening cable until it does. This adjustment should be made carefully to get the maximum performance from the carburetor. After the adjustment is made, tighten the adjuster jam nut.
- After adjusting the opening cable, turn the handlebars to the right and adjust the throttle free-play with the closing cable to approximately 1/8" (Figure 5).

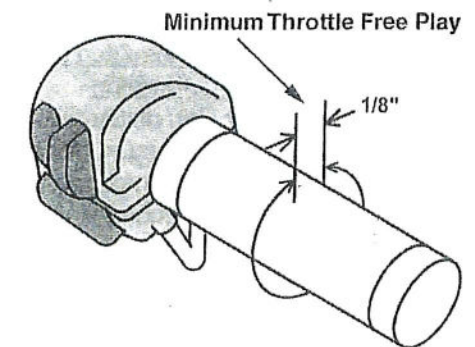

Figure 5