



HSR Carburetor Total Kits

Installation Instructions

HSR42 Kits:

#42-8	'84 - '99	Evo Big Twin
#42-19	'99 - present	Twin Cam

HSR45 Kits:

#45-2	'84 - '99	Evo Big Twin
#45-3	'84 - '99	Evo Big Twin
#45-4	'99 - present	Twin Cam

Total Kit Installation Instructions

The HSR series carburetors are precise yet durable instruments; however, like any other piece of fine equipment, they require correct installation and reasonable care to assure optimum performance and long life. Extra time spent during installation will pay off in both short and long term performance and reliability.

This Mikuni HSR carburetor kit is designed to be a bolt-on application, and as such, is set-up and jetted properly for most applications. However, since Harley-Davidson motors are often highly modified, alternate tuning settings may be required. The Mikuni Tuning Manual helps make jetting alterations and adjustments an easy matter.

NOTE: Carburetor Kits not designated as C.A.R.B. exempt, are not legal for motor vehicles operated on public highways in the state of California, or in any other states and countries where similar laws apply.

Notes, Cautions and Warnings:

Statements in this manual preceded by these words are very important:

NOTE:

Gives helpful information that can make a job easier.

CAUTION

Indicates a possibility of damage to vehicle if instructions are not followed.

WARNING

Indicates a possibility of personal injury or vehicle damage if instructions are not followed.

WARNING

Read these instructions carefully before you begin installation of your HSR kit. All procedures in this manual should be followed, paying particular attention to the following:

1. Mikuni HSR series carburetors require the use of a push/pull throttle assembly to assure closing of the throttle valve.
2. The throttle cables should be routed freely (without sharp bends) between the throttle twist grip and the carburetor and must not be pinched.
3. Gasoline is extremely flammable and is explosive under certain conditions. Do not install your Mikuni near open flame.
4. Never look directly into the bore of the carburetor while the engine is running as injury may result from possible backfire.

NOTE:

The Mikuni intake manifold, included in these kits, requires the flanges and seals from a '90 and later "Big Twin." If you do not have these parts, you will need to get them from a Harley-Davidson dealer. The required part numbers are:

- | | | |
|--------------|--------|-------|
| 1. 27009-86A | Flange | 1 ea. |
| 2. 27010-86A | Flange | 1 ea. |
| 3. 26995-86B | Seal | 2 ea. |

Disassembly:

1. Disconnect the battery ground wire from the battery.
2. Turn the fuel petcock to the "OFF" position.
3. Elevate the rear of the tank for better access.
4. Remove the coil, horn or other devices on the left side of the engine to gain access to the manifold bolts.
5. Remove the complete air cleaner assembly.
6. Disconnect any vacuum hoses and the fuel hose from the stock carburetor.
7. Disconnect the choke cable from the frame.
8. Remove the stock carburetor.
9. Evo: remove the stock manifold.
10. Twin Cam: unplug MAP sensor, remove manifold and then remove the MAP sensor from the manifold.

Installation:

NOTE:

Lubricate the manifold seals (liquid soap, oil or grease).

Intake Manifold:

1. Install MAP sensor in Mikuni manifold (Twin Cam only).
2. Attach the Mikuni manifold to the engine. Align the manifold before tightening the bolts. The flange surface of the Mikuni manifold should be parallel with the front of the engine's cam cover. Use a level or angle meter to check this. Tighten the manifold bolts.
3. Attach the rubber flange to the Mikuni manifold with the furnished 5/16"x3/4" bolts and washers.

Choke Cables: Mikuni & Harley-Davidson

NOTE:

Route the cable with largest radius bends possible. Check the cable for free-play after installation. If there is no free-play, the engine may run rich and deliver poor performance or low fuel mileage.

Harley Cable (Twin Cam Kits: 42-19, 45-4):

1. Remove the Harley choke cable from the stock carb.
2. Remove the spring and plunger from the cable.
3. Remove the spring and plunger from the Mikuni.
5. Install the Mikuni spring and plunger onto the Harley choke cable. Change nothing else; be sure to use the Harley plastic nut, not the Mikuni nut (See Figure 1).

6. Install the new assembly into the Mikuni carburetor. Be careful to only gently tighten the plastic nut.
7. Loosen the knurled plastic friction nut behind the choke knob and check for free-play (see Figure 2).



Figure 1: Harley nut with Mikuni spring & plunger

Stock Choke Cable

Loosen plastic friction nut to check cable free-play

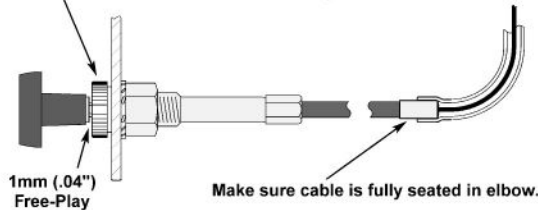

Mikuni Choke Cable

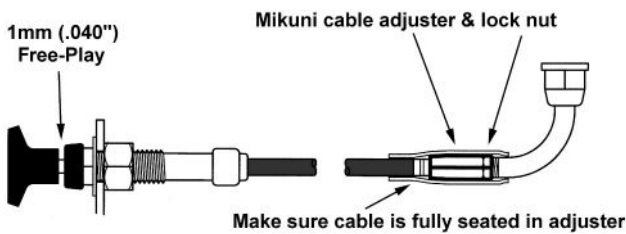

Figure 2: Choke cable adjustments

Mikuni Cable (Evo Kits: 42-8, 45-2 & 45-3):

1. Remove nut, spring and plunger from the Mikuni.
2. Install the nut, spring and plunger onto the cable.
3. Install the assembly into the Mikuni HSR carburetor. Be careful to only gently tighten the plastic nut.
4. Check for free-play. Adjust the cable as necessary.

NOTE:

An optional choke cable mounting bracket is included in the Evo kits for custom installations.

Carburetor Installation:

1. Insert the carb fully into the rubber flange, align with engine and tighten the clamp.
2. Slip the fuel hose onto the carburetor's fuel fitting and secure with the enclosed hose clamp.

NOTE:

Some Twin Cam installations may require removal of a small amount of fin material from the cylinders to clear the float bowl.

Throttle Cables

The HSR carburetor uses stock 1990 and later Harley-Davidson cables. However, if your Harley is fitted with some other carburetor, you may need to purchase a set of cables. See your dealer for the correct cable set.

1. Route the throttle cables with large radius curves and so they do not interfere with other components.
2. Screw the cable adjusters together to make them as short as possible.
3. Connect the "close" cable first (see Figure 3).
4. Install the "open" cable next (see Figure 3).

5. Adjust the opening cable until the slide can be opened fully. Snug the adjuster lock nut.
6. Turn the handlebar to the right and adjust the throttle free-play with the closing cable adjuster to approximately 1/8" (see Figure 4).

WARNING

The control cables must not pull tight when the handlebar is turned fully left and right. Also, be sure that the cables clear the fork stops at the steering head so they are not pinched when the handlebar is turned.

There must be some free-play at all handlebar positions to avoid binding in the throttle cables. Binding causes excessive wear and interferes with precise throttle control.

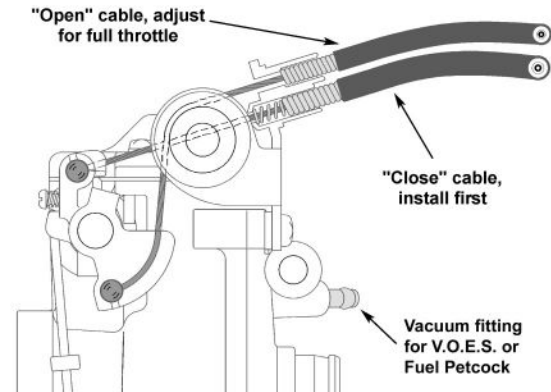

Figure 3: Cable installation guide

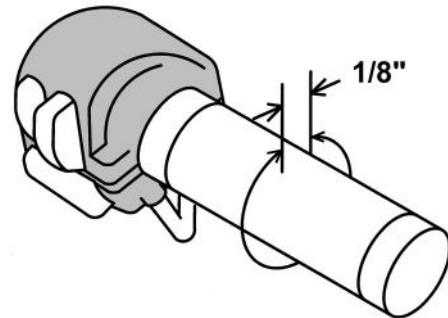

Figure 4: Throttle free-play

Cable Lube:

Remove upper throttle housing and lube each cable.

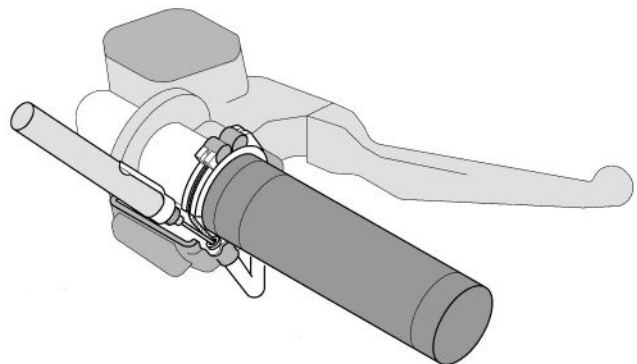

Figure 5: Cable lube procedure

CAUTION

Cable lubrication is important. Dry cables can result in sticky throttle action, slow return to idle and excessive cable wear.

TK-3

Air Cleaner and Breather:

Use the supplied brackets, breather kit parts, O-rings, bolts & washers as required. See illustrations below.

Evo Engines: KHS-020 breather kit

'84-'91: Use 2 ea. 5/16"x3/4" bolts, washers and O-rings.

'92: Use 2 ea. 1/2"x3/4" bolts and flat washers.

'93-'99: Add the included breather kit (KHS-020).

TwinCam: KHS-030 breather kit.

1. Loosely attach the brackets and/or breather parts to the cylinder heads with the appropriate hardware.
2. Remove the rubber stud protectors from the Mikuni air filter and place the two backing plates on the studs. Position the air filter up to the carburetor while aligning the brackets with the filter studs. Once the filter is in place, tighten the filter clamp. Then, secure the filter to the brackets with the enclosed 5/16" nuts and flat washers (see Figure 9).
3. Cut out the thin membranes in the back of the filter and insert the plastic elbows. Use the 5/16" i.d. hose to connect the elbows to the breather fittings.
4. Use the stock cover screw to attach the Mikuni air cleaner cover to the air filter.

Hose Routing:

1. Use the kit's hose clamps to secure the fuel hose to the petcock and carburetor. Fit the screw clamp to the petcock end and the spring clamp to the carb.
2. **Evo:** Fit the V.O.E.S. or petcock hose to the carburetor. A piece of vacuum hose is included in the kit
3. **Twin Cam:** Attach the petcock vacuum hose to the carburetor.
4. Route the float bowl overflow hose below the engine. Do not connect this hose to any other hoses.

CAUTION

1. If you are not using the V.O.E.S., seal the Vacuum Fitting on the carburetor.
2. The Vent Fitting located above the Fuel Fitting *must not* be sealed! Sealing it results in erratic air/fuel mixture ratios, poor performance and possible engine damage.

NOTE:

You may have some hoses remaining after your installation. Since this is a performance application only, some hoses and related hardware may no longer be required.

Starting:

Re-connect the battery and re-assemble the remainder of the motorcycle. Turn the petcock on and start the engine as you normally would (be sure the throttle is fully closed). After it is warm, set the idle to the recommended 1,000 to 1,100 rpm. To learn more about adjusting your HSR carburetor, refer to the included Tuning Manual.

Air Cleaner Element Care:

Inspect and, if necessary, clean the air filter every 5,000 miles. The K&N brand filter supplied with this kit is very effective. It removes extremely small dirt particles yet does not substantially interfere with air flow into the engine. When you clean the filter, be sure to follow the cleaning instructions included with this kit.

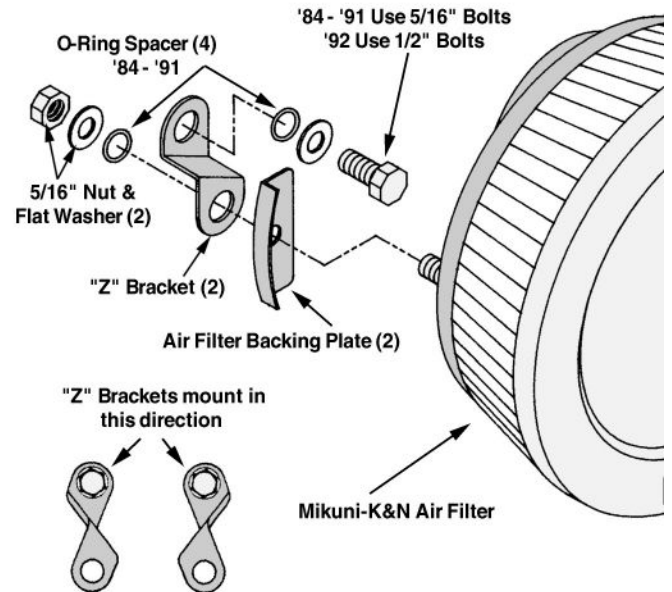

Figure 6: Air cleaner assembly guide

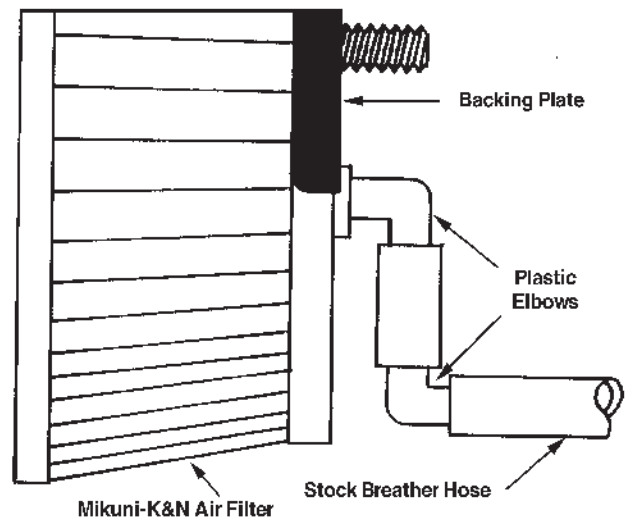

Figure 7: '84 - '92 breather installation

Kit Contents:

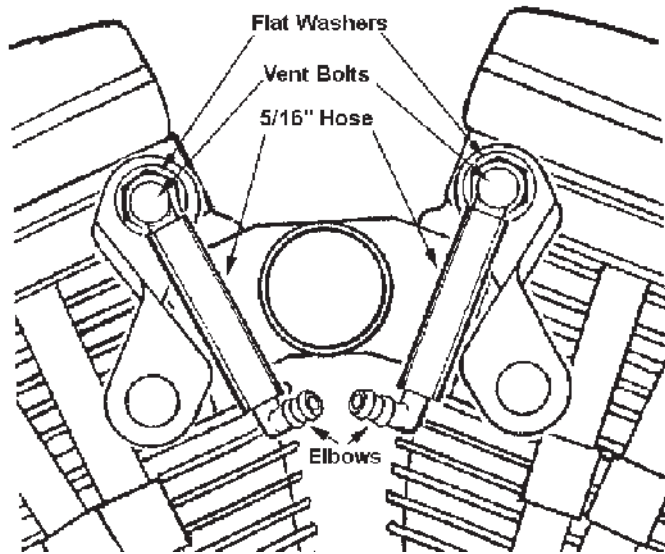

Figure 8: '93 - '99 Evo breather (KHS-020)

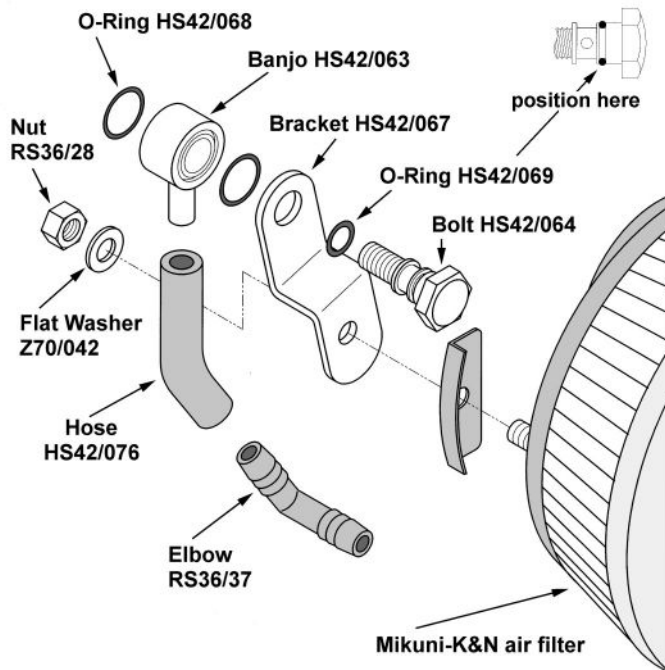

Figure 9: Twin Cam breather (KHS-030)

Twin Cam:

Kit: 42-19 45-4

TM42-6	Carburetor	1	
TM45-2	Carburetor		1
HS42/012	Air Filter, 2-1/2"	1	
HS42/012-300	Air Filter, 3"		1
HS42/02-250-CHR	Cover A/C (Chrome)	1	1
HS42/061-45TC	Manifold	1	1
HS42/062-42	Rubber Flange	1	
HS42/062-45	Rubber Flange		1
KHS-030	Breather Kit	1	1
N100.604-155	Main Jet	1	
N100.604-165	Main Jet	1	
N100.604-170	Main Jet		1
N100.604-180	Main Jet		1
RS36/47	Plate, Back	2	2
Z70/042	Flat Washer, 5/16"	2	2
Z70/045	Hose Clamp	1	1
Z70/05512	Hose, Fuel	1	1
Z70/146	Nylon Cable Tie	4	4
HS42/073	Cable Lube	1	1
RS36/27-075	Bolt, Hex 5/16"x3/4"	2	2

Evo:

Kit: 42-8 45-2

TM42-6	Carburetor	1	
TM45-2	Carburetor		1
HS42/012	Air Filter, 2-1/2"	1	
HS42/012-300	Air Filter, 3"		1
HS42/019	Bracket, Air Filter	2	2
HS42/021-250-CHR	Cover A/C	1	1
HS42/034	O-ring	4	4
HS42/037	Bolt, 1/2"-13 x 1"	2	2
HS42/038	1/2" Washer	2	2
HS42/061-45	Manifold	1	1
HS42/062-42	Rubber Flange	1	
HS42/062-45	Rubber Flange		1
KHS-020	Breather Kit	1	1
N100.604-155	Main Jet	1	
N100.604-165	Main Jet	1	
N100.604-170	Main Jet		1
N100.604-180	Main Jet		1
RS36/02-17	Hose Clamp	1	1
RS36/23	Choke Bracket	1	1
RS36/27-075	Bolt, 5/16" x 3/4"	4	4
RS36/28	Nut, 5/16"	2	2
RS36/3609	Hose, 3/16" x 9"	1	1
RS36/37	Elbow, Plastic, 3/8"	2	2
RS36/47	Plate, Back	2	2
RS36/54	Screw, Cover	1	1
Z70/042	Flat Washer, 5/16"	6	6
Z70/045	Hose Clamp	1	1
Z70/05512	Hose, Fuel	1	1
Z70/146	Cable Tie, 7-1/2"	4	4
990-662-002	Choke Cable Assy	1	1
HS42/073	Cable Lube	1	1

Note: The 45-3 Kit does not include a manifold. Otherwise, it is identical to the 45-2 Kit.

HSR PARTS LIST

#	PART NO.	DESCRIPTION		
1.	C5=0410-B	Screw, Top Cover	51.	VM12/205 Washer, Pilot Air
2.	CW2=0414-B	Screw, Top Cover	52.	N133.037 O-Ring, Pilot Air
3.	776-39005	Top Cover	53.	TM40/27 Fuel Joint
4.	TM42/04	Gasket, Top Cover	54.	KV10 O-Ring, Fuel Joint
5.	BS32/126	E-Ring, Jet Needle	55.	B30/398 Packing, Idle Adjuster
6.	826-03002	Washer, Jet Needle	56.	VM22/138 Washer, Idle Adjuster
7.	J8-8DDY01-97	Jet Needle (42)	57.	730-09018 Spring, Idle Adjuster
7a.	J8-8CFY02-97	Jet Needle (45/48)	58.	925-15001 Ring, Idle Adjuster
8.	TM42/03	Lever, T.V. (42/45)	59.	TM42/32 Idle Adjuster (Long)
8a.	TM42/08-1A	Lever, T.V. (48)	59a.	990-605-065 Idle Adjuster (Short)
9.	B40I/56	E-Ring, Link Lever	60.	BS30/97-00 Air Jet (Blank)
10.	B40I/10	Packing, Link Lever	61.	784-430000-Y-6 Needle Jet (723)
11.	834-23041	Pin, Link Lever	62.	TM42/11-70 Nozzle, Accel. Pump
12.	TM42/08-3.0	Throttle Valve (Slide)	63.	N124.063 O-Ring, A/P
13.	739-13002	Screw, Needle Retainer	64.	VM28/486-25 Pilot Jet
14.	TM42/16	Clip, Needle Retainer	65.	TM42/12 Extender, Main Jet (42/45)
15.	TM42/13	Sealing Ring, T.V. (42/45)	65a.	TM42/12-1A Extender, Main Jet (48)
15a.	TM48/02	Sealing Ring, T.V. (48)	66.	N100.604-160 Main Jet
16.	TM42/10	Seal, Throttle Valve	67.	616-33003 O-Ring N.V.
17.	925-98006	Pulley, Cable Bracket	68.	VM13/216 Screw, N.V. Retainer
18.	53974	E-Ring, Cable Bracket	69.	786-27001-4.2 Needle Valve Ass'y (42/45)
19.	TM42/51	Bracket Ass'y, Cable	69a.	786-27002-1A Needle Valve Ass'y (48)
19a.	TM42/53	Bracket Ass'y, Sportster	70.	859-32027 Float Ass'y
20.	B3=0520-B	Bolt, Bracket	71.	BV26/22 Pin, Float
21.	VM28/204	Spacer, Bracket	72.	C2=0410 Screw, Float Pin
22.	TM42/38	Plate, Lock Tab	73.	616-94028 Packing, Float Bowl
23.	C2=0514-B	Screw	74.	TM42/05 Float, Chamber Body
24.	640-12001	Starter Nut, Choke	75.	N122.028 Hose, Overflow
25.	VM14/241	Spring, Starter Plunger	76.	VM28/254 O-Ring, Drain Plug
26.	N189.192	Starter Plunger	77.	TM32/41 Drain plug (42/45)
27.	TM42/06	Body, Bearing & Spigot (42/45)	77a.	TM32/41-1D Drain Plug (48)
27a.	TM48/02	Body, Bearing & Spigot (48)	78.	C2=0412-B Screw, Flt Bowl, short
28.	616-94029	Seal, Spigot Body	79.	TM36/44-1A Rod, A/P
29.	925-19011	Ring (Steel)	80.	TM36/64 Boot, A/P Rod
30.	TM42/43	Lever, A/P	81.	TM36/60 Plunger, A/P
31.	N138.019	Pin, Throttle Lever	82.	VM14SC13/89 Spring, A/P
32.	TM42/48	Lever, Throttle	83.	N198.063 Rubber Cap, Purge Port
33.	M12F/46-BB	Spring, A/P		
34.	MC-0316-B	Screw, A/P		
35.	TM42/47	Spring, A/P		
36.	TM42SS1/01-0	Mixing Body (42/45)		
36a.	TM48SS1/01	Mixing Body (48)		
37.	B36/95	Packing, Shaft (Plastic)		
38.	TM42/36	Adjusting Screw, A/P		
39.	B30/205	O-Ring, A/P Screw		
40.	TM40/89	Bolt		
40a.	TM42/17	Plate, Lock Tab for Shaft		
41.	BN38/43	Pin, Return Lever		
42.	TM42/46	Lever, Return		
43.	B30/1069	Adjusting Screw, Throttle		
44.	N3=04	Nut, Throttle Stop		
45.	TM42/19	Spring, Throttle Return		
46.	700-15012	Shaft, Throttle		
47.	TM42/15	Plate, Fuel Joint Retainer		
48.	C2=0410-B	Screw, Fuel Joint		
49.	604-26014	Screw, Pilot Air		
50.	N133.206	Spring, Pilot Air		

Alternate Parts**Jet Needles:****HSR42****HSR45/48**

J8-8DDY01-95	J8-8CFY02-95	Richer
J8-8DDY01-96	J8-8CFY02-96	Richer
J8-8DDY01-97	J8-8CFY02-97	Std
J8-8DDY01-98	J8-8CFY02-98	Leaner

Accelerator Pump Nozzles:

TM42/11-70	Std
TM42/11-60	Leaner
TM42/11-50	Leaner

Needle Valve Assemblies:

786-27002-1A-4.5	Std (HSR48)
786-27001-4.2	Std (HSR42/45)
786-27001-3.5	Smaller
786-27001-2.3	Pressure only

Rebuild Kit:

HSR42/45:	KHS-016
HSR48:	KHS-031

NOTE:

1. Lined through part numbers are not available.
2. **Parts in bold** are included in rebuild kits.

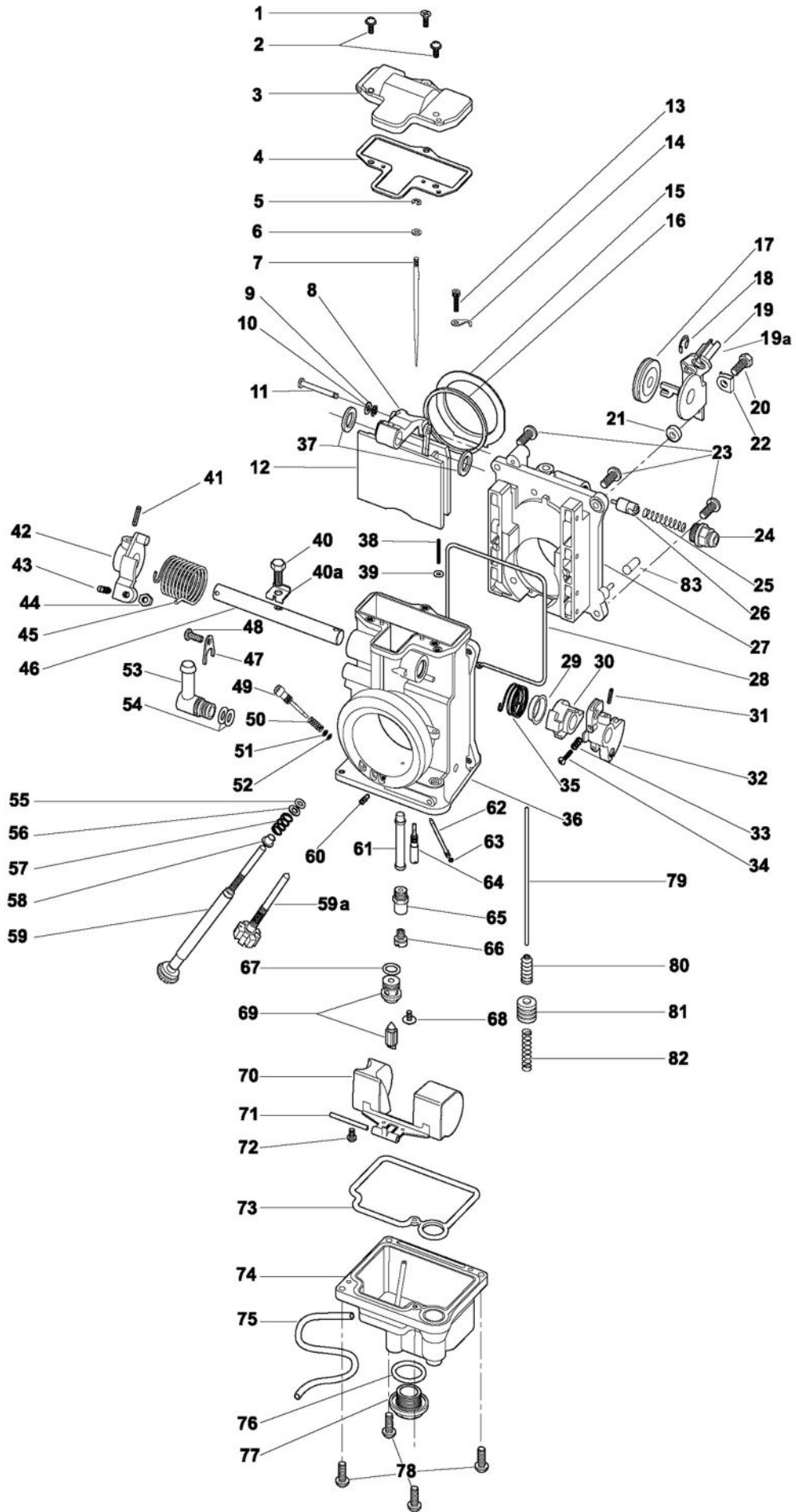

Mikuni American Corporation
8910 Mikuni Avenue
Northridge, CA 91324-3496
www.mikuni.com