



HSR Carburetor
Sportster/Buell
Installation Instructions

Carb Kit: 42-10
Carb Kit: 42-11

'94 -- present Sportster
All Carbureted 1200 Buells

Sportster/Buell Installation

The HSR series carburetors are precise yet durable instruments; however, like any other piece of fine equipment, they require correct installation and reasonable care to assure optimum performance and long life. Extra time spent during installation will pay off in both short and long term performance and reliability.

This Mikuni HSR carburetor kit is designed to be a bolt-on application, and as such, is set-up and jetted properly for many applications. However, since many Harley-Davidson motors are highly modified, re-tuning may sometimes be necessary. The Mikuni Tuning Manual helps make jetting alteration and adjustments an easy matter.

NOTE: *Carburetor Kits not designated as C.A.R.B. exempt, are not legal for motor vehicles operated on public highways in the state of California, or in any other states and countries where similar laws apply.*

Application: Sportster and Buell motorcycles (Sportsters must have petcock on left side of the fuel tank).

Notes, Cautions and Warnings

Statements in this manual preceded by these words are very important:

NOTE:

Gives helpful information that can make a job easier.

CAUTION

Indicates a possibility of damage to vehicle if instructions are not followed.

WARNING

Indicates a possibility of personal injury or vehicle damage if instructions are not followed.

WARNING

Read these instructions carefully before you begin installation of your HSR kit. All procedures should be followed, paying particular attention to the following:

1. Mikuni HSR series carburetors require the use of a push/pull throttle assembly to assure closing of the throttle valve.
2. The throttle cables should be routed freely (without sharp bends) between the throttle twist grip and the carburetor and must not be pinched.
3. Gasoline is extremely flammable and is explosive under certain conditions. Do not install your Mikuni near open flame.
4. Never look directly into the bore of the carburetor while the engine is running as injury may result from possible backfire.

Disassembly:

1. Disconnect the battery ground wire from the battery.
2. Turn the fuel petcock to the "OFF" position.
3. Disconnect any vacuum hoses and the fuel hose from the stock carburetor.
4. Remove the fuel tank.
5. Remove the complete air cleaner assembly, including the backing plate.
6. Remove the stock carburetor together with the choke cable.
7. Sportster only: remove the V.O.E.S. from its normal location.

Installation:

Choke Cable to Carburetor:

1. Remove the choke cable from the stock carburetor.
2. Remove the Harley spring and plunger from the Harley choke cable.
3. Remove the Mikuni spring and plunger from the Mikuni carburetor.
5. Install the Mikuni spring and plunger onto the Harley choke cable. Change nothing else; be sure to use the Harley plastic nut, not the Mikuni nut.
6. Install the new assembly into the Mikuni. Be careful to only gently tighten the plastic nut.



Figure 1: Harley nut with Mikuni spring & plunger

NOTE:

Carburetor to Manifold:

It is easier to fit the throttle cables to the carburetor before mounting the carburetor. Cable adjustment should wait until after the carburetor is mounted.

1. Inspect the manifold seal for damage. If it is nicked or distorted, replace it with a new seal.
2. Lubricate the seal and carburetor spigot with rubber lube, chassis grease or motor oil.
3. Insert the carburetor into the manifold. The fit is tight and a pushing --- twisting motion works well.
4. Align the carb vertically. The mouth of the carburetor should be parallel with front of the ignition cover on the crankcase.
5. Route and install the choke cable. Make sure that the choke cable is fully bottomed and that it has free-play as shown in Figure 5.

Throttle Cables:

NOTE:

The HSR Sportster carburetor uses the same cables that fit the stock CV (constant velocity) carburetor Harley-Davidson has been fitting to Sportsters since 1988.

1. Route the throttle cables with large radius curves and so that they do not interfere with other components. Use Figure 2 as a guide.
2. Screw the cable adjusters together to make them as short as possible.
3. Connect the "close" cable first (see Figure 3).
4. Install the "open" cable next (see Figure 3).
5. Adjust the opening cable until the slide can be opened fully. Snug the adjuster lock nut.
6. Turn the handlebar to the right and adjust the throttle free-play with the closing cable adjuster to approximately 1/8" (see Figure 4).

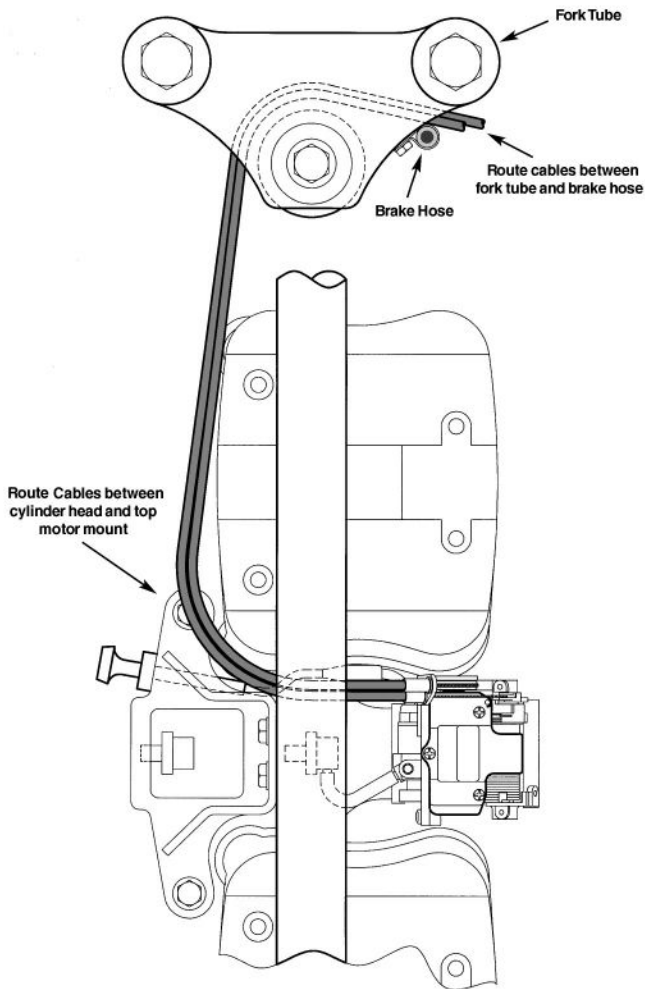

Figure 2: Cable Routing Guide

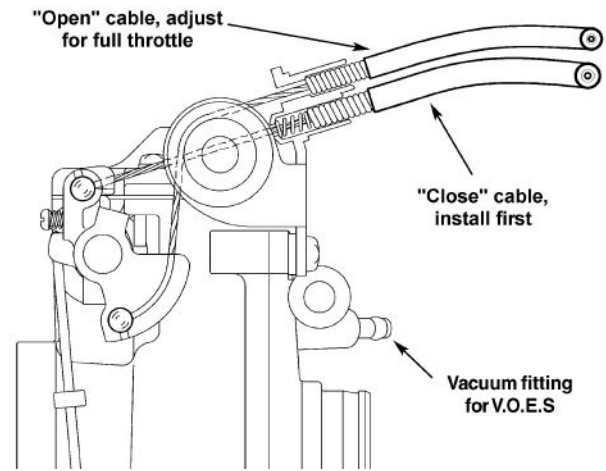

Figure 3: Cable installation guide

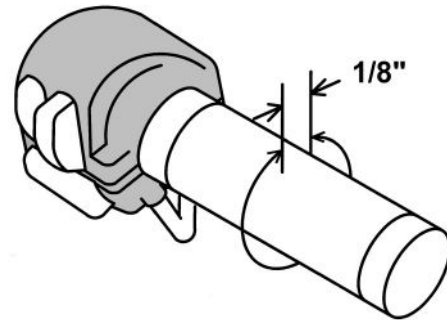

Figure 4: Throttle free-play

CAUTION

1. The control cables must not pull tight when the handlebar is turned fully left and right. Also, be sure that the cables clear the fork stops at the steering head so they are not pinched when the handlebar is turned.
2. It is important to check for adequate clearance between the cable elbows and the gas tank when the handlebar is turned from lock to lock.

WARNING

There must be some free play at all handlebar positions to avoid binding in the throttle cables.

SB-3

Choke Cable Final Assembly:

1. Feed the choke cable to the left side of the chassis.
2. Fit the cable into its holder on the top motor mount (see Figure 5). Be sure that the lock washer is between the nut and the motor mount.
3. Gently tighten the nut. The threaded body of the choke cable assembly is relatively fragile plastic.
4. Make sure that the flexible portion of the cable is bottomed in the metal elbow that leads into the carburetor. This junction (cable/elbow) is covered by a rubber boot and it may be necessary to peel the boot back for inspection.
5. Slightly loosen the plastic friction nut located behind the choke knob.
6. Move the choke knob in and out to make sure there is free-play in the cable. If you cannot detect any free-play before feeling the resistance of the choke spring, recheck the cable routing.

NOTE:

An unseated plunger may result in poor fuel economy, irregular idle and plug fouling.

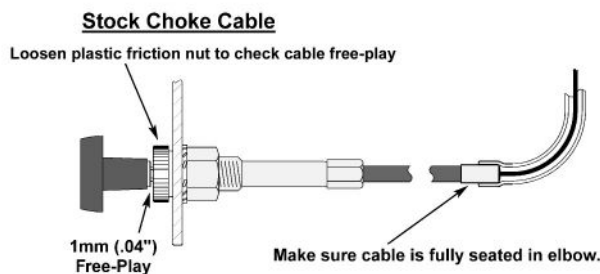

Figure 5: Choke cable free-play

Cable Lube:

Remove upper throttle housing and inject cable lube into each cable.

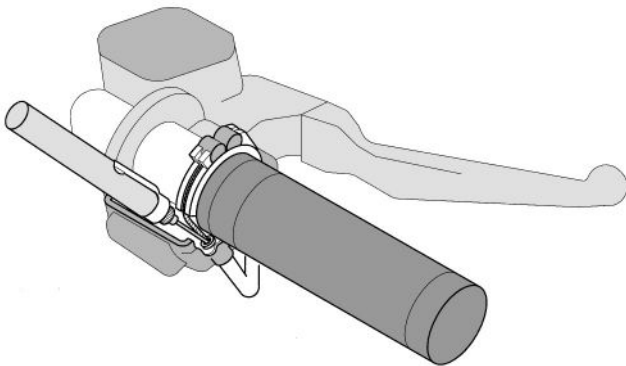

Figure 6: Cable lube procedure

CAUTION

Cable lubrication is important. Dry cables can result in sticky throttle action, slow return to idle and excess wear.

Mikuni Air Cleaner (Sportster):

1. Fit the large O-ring into the Mikuni adapter.
2. Use the short Mikuni screws to attach the adapter and stock gasket to the Mikuni Backing Plate. **Do Not** use the stock screws, they are too long.
3. Attach the hex spacers to the backing plate using the furnished 5/16" bolts, lock and flat washers.
4. Attach the backing plate assembly to the engine using the stock vent bolt together with the furnished lock washers, short and long spacers (see Figure 7).
5. Fit the air cleaner element and filter cover using the stock screws.
6. NOTE: We recommend that you use a K&N brand filter element for maximum air flow and performance.

WARNING

The stock air cleaner assembly cannot be used with the HSR carburetors. The stock backing plate interferes with the throttle linkage of the Mikuni. Most after market air filter kits should work. However, since Mikuni is not in a position to test every air cleaner kit on the market, we cannot assure you that all such kits fit our carburetor.

Buell/Sportster with Screamin' Eagle:

1. Fit the large O-ring into the Mikuni adapter.
2. Attach the adapter to your selected air cleaner backing plate using the supplied screws. **Do Not** use the stock screws. They are too long.
3. Proceed with the factory instructions for your air cleaner.

NOTE:

1. Carefully check to make sure that your air cleaner installation does not interfere with the proper operation of the throttle linkage. The linkage must be free to move as intended.
2. Since there are a number of variations in Buell air filter installations, we urge you to take the extra time required to ensure a safe installation.

CAUTION

The Vent Fitting located above the Fuel Fitting must not be sealed! Sealing it results in erratic air-fuel mixture ratios, poor performance and possible engine damage.

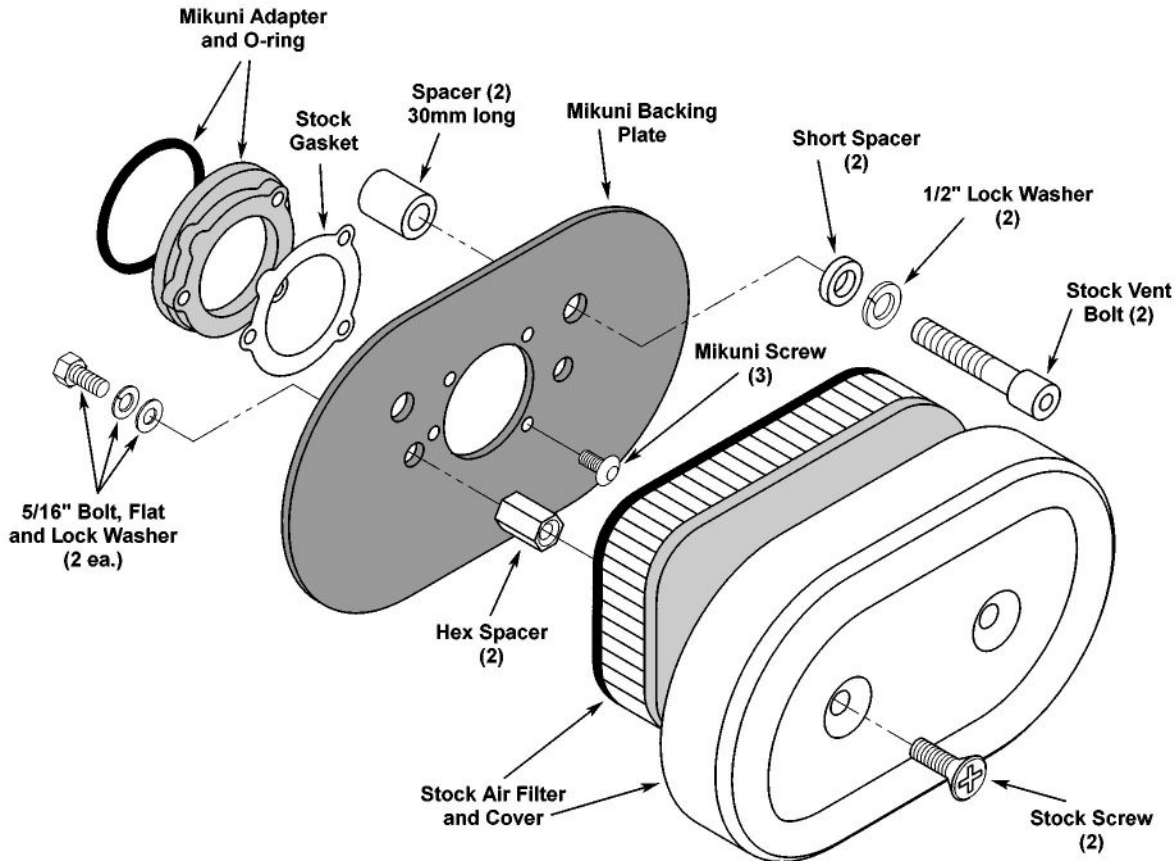

Figure 7: Air Cleaner Ass'y

V.O.E.S. (Sportster Only):

1. Use a pick or small screwdriver to carefully pry the special retaining washer off the VOES.
2. Rotate the VOES so that the vacuum line points downward (see Figure 8). Note that the VOES and its mounting bracket have indexing bumps and notches that must be aligned.
3. Press the retention washer back into place.
4. Remove the stock vacuum hose and fit the longer hose furnished in the kit. Trim the new hose to fit onto the HSR vacuum fitting shown in Figure 3.
5. Sandwich the VOES assembly between the horn and the horn mounting bracket as shown in Figure 8 below.

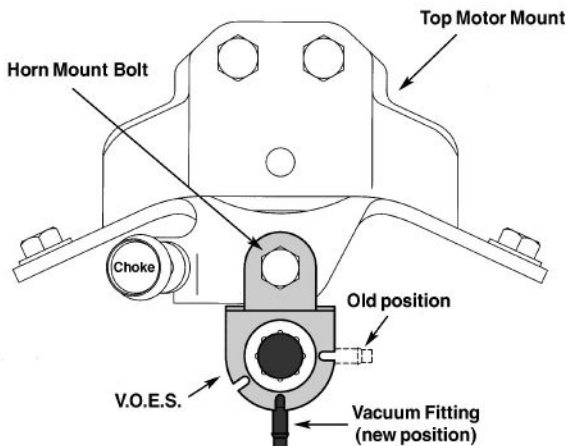

Figure 8: V.O.E.S. Installation

Kit Contents:

Sportster/Buell: 42-10, 42-11

Part#	Description	Qty.	
		42-10	42-11
TM42-6	Carburetor	1	1
HS42/001	Adaptor, air cleaner	1	1
HS42/003	O-Ring, Adaptor	1	1
HS42/048	Screw, Adaptor	3	3
N100.604-155	Main Jet	1	1
N100.604-165	Main Jet	1	1
Z70/146	Cable Tie	3	3
Z70/045	Hose Clamp	1	1
HS42/073	Cable Lubricant	1	1
HS42/045	Back Plate	1	
HS42/046	Collar, 30mm	2	
HS42/047	Spacer, Hex	2	
HS42/049	Spacer, 1/4"	2	
HS42/050	Lockwasher	2	
RS36/27-075	Bolt, 5/16" x 3/4"	2	
Z70/042	Flat Washer	2	
Z70/043	Lock Washer	2	
RS36/3609	Hose, Vacuum Fitting	1	1

HSR PARTS LIST

#	PART NO.	DESCRIPTION		
1.	C5=0410-B	Screw, Top Cover	51.	VM12/205 Washer, Pilot Air
2.	CW2=0414-B	Screw, Top Cover	52.	N133.037 O-Ring, Pilot Air
3.	776-39005	Top Cover	53.	TM40/27 Fuel Joint
4.	TM42/04	Gasket, Top Cover	54.	KV10 O-Ring, Fuel Joint
5.	BS32/126	E-Ring, Jet Needle	55.	B30/398 Packing, Idle Adjuster
6.	826-03002	Washer, Jet Needle	56.	VM22/138 Washer, Idle Adjuster
7.	J8-8DDY01-97	Jet Needle (42)	57.	730-09018 Spring, Idle Adjuster
7a.	J8-8CFY02-97	Jet Needle (45/48)	58.	925-15001 Ring, Idle Adjuster
8.	TM42/03	Lever, T.V. (42/45)	59.	TM42/32 Idle Adjuster (Long)
8a.	TM42/08-1A	Lever, T.V. (48)	59a.	990-605-065 Idle Adjuster (Short)
9.	B40I/56	E-Ring, Link Lever	60.	BS30/97-00 Air Jet (Blank)
10.	B40I/10	Packing, Link Lever	61.	784-430000-Y-6 Needle Jet (723)
11.	834-23041	Pin, Link Lever	62.	TM42/11-70 Nozzle, Accel. Pump
12.	TM42/08-3.0	Throttle Valve (Slide)	63.	N124.063 O-Ring, A/P
13.	739-13002	Screw, Needle Retainer	64.	VM28/486-25 Pilot Jet
14.	TM42/16	Clip, Needle Retainer	65.	TM42/12 Extender, Main Jet (42/45)
15.	TM42/13	Sealing Ring, T.V. (42/45)	65a.	TM42/12-1A Extender, Main Jet (48)
15a.	TM48/02	Sealing Ring, T.V. (48)	66.	N100.604-160 Main Jet
16.	TM42/10	Seal, Throttle Valve	67.	616-33003 O-Ring N.V.
17.	925-98006	Pulley, Cable Bracket	68.	VM13/216 Screw, N.V. Retainer
18.	53974	E-Ring, Cable Bracket	69.	786-27001-4.2 Needle Valve Ass'y (42/45)
19.	TM42/51	Bracket Ass'y, Cable	69a.	786-27002-1A Needle Valve Ass'y (48)
19a.	TM42/53	Bracket Ass'y, Sportster	70.	859-32027 Float Ass'y
20.	B3=0520-B	Bolt, Bracket	71.	BV26/22 Pin, Float
21.	VM28/204	Spacer, Bracket	72.	C2=0410 Screw, Float Pin
22.	TM42/38	Plate, Lock Tab	73.	616-94028 Packing, Float Bowl
23.	C2=0514-B	Screw	74.	TM42/05 Float, Chamber Body
24.	640-12001	Starter Nut, Choke	75.	N122.028 Hose, Overflow
25.	VM14/241	Spring, Starter Plunger	76.	VM28/254 O-Ring, Drain Plug
26.	N189.192	Starter Plunger	77.	TM32/41 Drain plug (42/45)
27.	TM42/06	Body, Bearing & Spigot (42/45)	77a.	TM32/41-1D Drain Plug (48)
27a.	TM48/02	Body, Bearing & Spigot (48)	78.	C2=0412-B Screw, Flt Bowl, short
28.	616-94029	Seal, Spigot Body	79.	TM36/44-1A Rod, A/P
29.	925-19011	Ring (Steel)	80.	TM36/64 Boot, A/P Rod
30.	TM42/43	Lever, A/P	81.	TM36/60 Plunger, A/P
31.	N138.019	Pin, Throttle Lever	82.	VM14SC13/89 Spring, A/P
32.	TM42/48	Lever, Throttle	83.	N198.063 Rubber Cap, Purge Port
33.	M12F/46-BB	Spring, A/P		
34.	MC-0316-B	Screw, A/P		
35.	TM42/47	Spring, A/P		
36.	TM42SS1/01-0	Mixing Body (42/45)		
36a.	TM48SS1/01	Mixing Body (48)		
37.	B36/95	Packing, Shaft (Plastic)		
38.	TM42/36	Adjusting Screw, A/P		
39.	B30/205	O-Ring, A/P Screw		
40.	TM40/89	Bolt		
40a.	TM42/17	Plate, Lock Tab for Shaft		
41.	BN38/43	Pin, Return Lever		
42.	TM42/46	Lever, Return		
43.	B30/1069	Adjusting Screw, Throttle		
44.	N3=04	Nut, Throttle Stop		
45.	TM42/19	Spring, Throttle Return		
46.	700-15012	Shaft, Throttle		
47.	TM42/15	Plate, Fuel Joint Retainer		
48.	C2=0410-B	Screw, Fuel Joint		
49.	604-26014	Screw, Pilot Air		
50.	N133.206	Spring, Pilot Air		

Alternate Parts

Jet Needles:

HSR42 HSR45/48

J8-8DDY01-95 J8-8CFY02-95 Richer
 J8-8DDY01-96 J8-8CFY02-96 Richer
 J8-8DDY01-97 J8-8CFY02-97 Std
 J8-8DDY01-98 J8-8CFY02-98 Leaner

Accelerator Pump Nozzles:

TM42/11-70 Std
 TM42/11-60 Leaner
 TM42/11-50 Leaner

Needle Valve Assemblies:

786-27002-1A-4.5 Std (HSR48)
 786-27001-4.2 Std (HSR42/45)
 786-27001-3.5 Smaller
 786-27001-2.3 Pressure only

Rebuild Kit:

HSR42/45: **KHS-016**
 HSR48: **KHS-031**

NOTE:

1. Lined-through-part numbers are not available.
2. **Parts in bold** are included in rebuild kits.

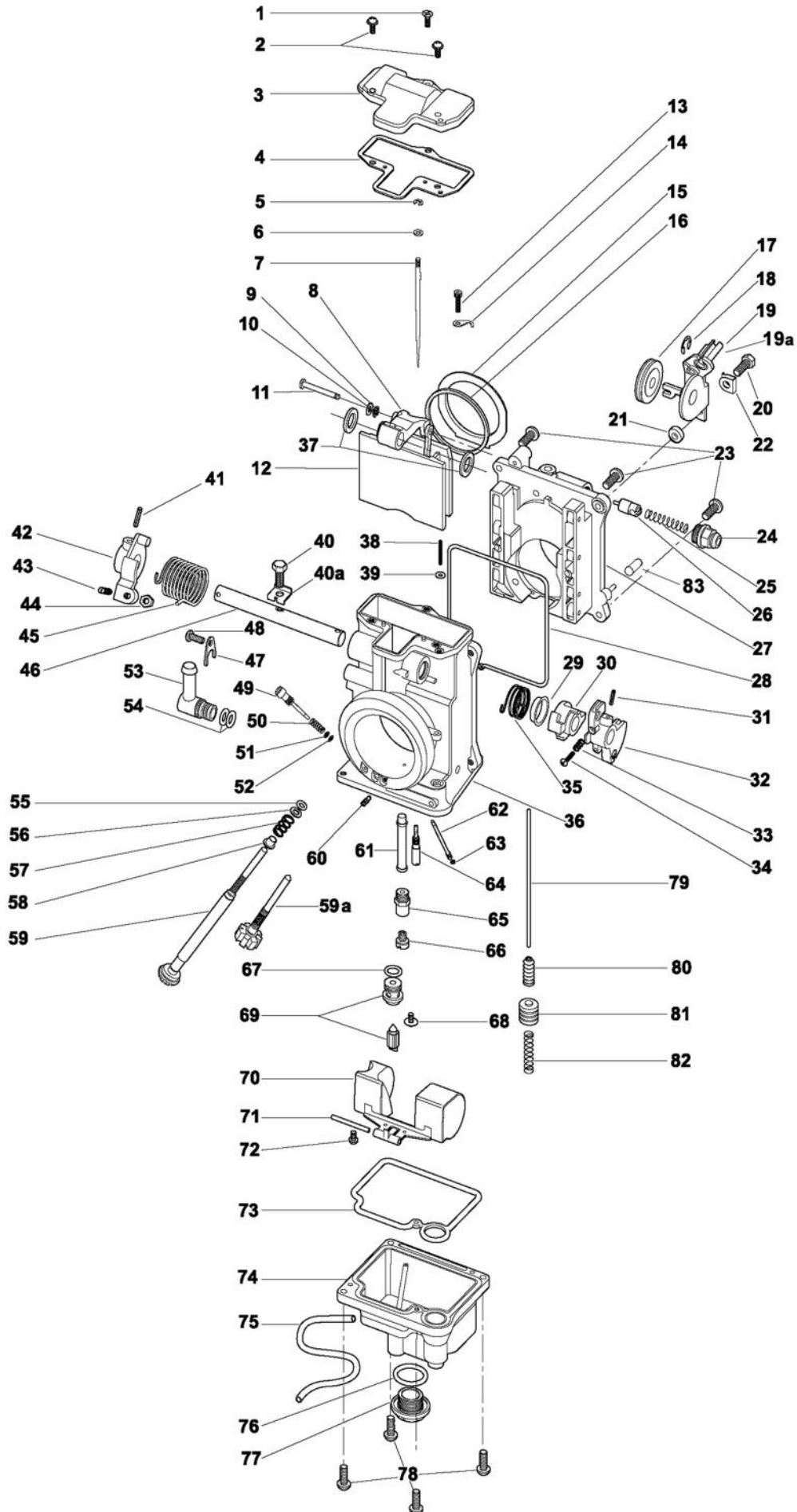

Mikuni American Corporation

8910 Mikuni Avenue

Northridge, CA 91324-3496

www.mikuni.com