

HSR Series Carbs

42/45/48 Smoothbore Carburetors

Going fast has never been so easy! The number one performance carburetor for Harley-Davidsons and American Big Twins now slips onto any late model Harley-Davidson using the original throttle cables. Mikuni's Twin Cam, Big Twin and Sportster / Buell Easy Kits even use Harley's existing manifold, choke cable and air filter.

Keep a Harley's stock factory look and fit with better throttle response, improved acceleration, increased power and torque. Mikuni's smoothbore, flatslide throttle with roller bearings, and accelerator pump technology delivers peak performance from idle to Wide Open Throttle.

Available in 42, 45, and 48mm throttle bores for use with stock, mild, and highly modified engines.

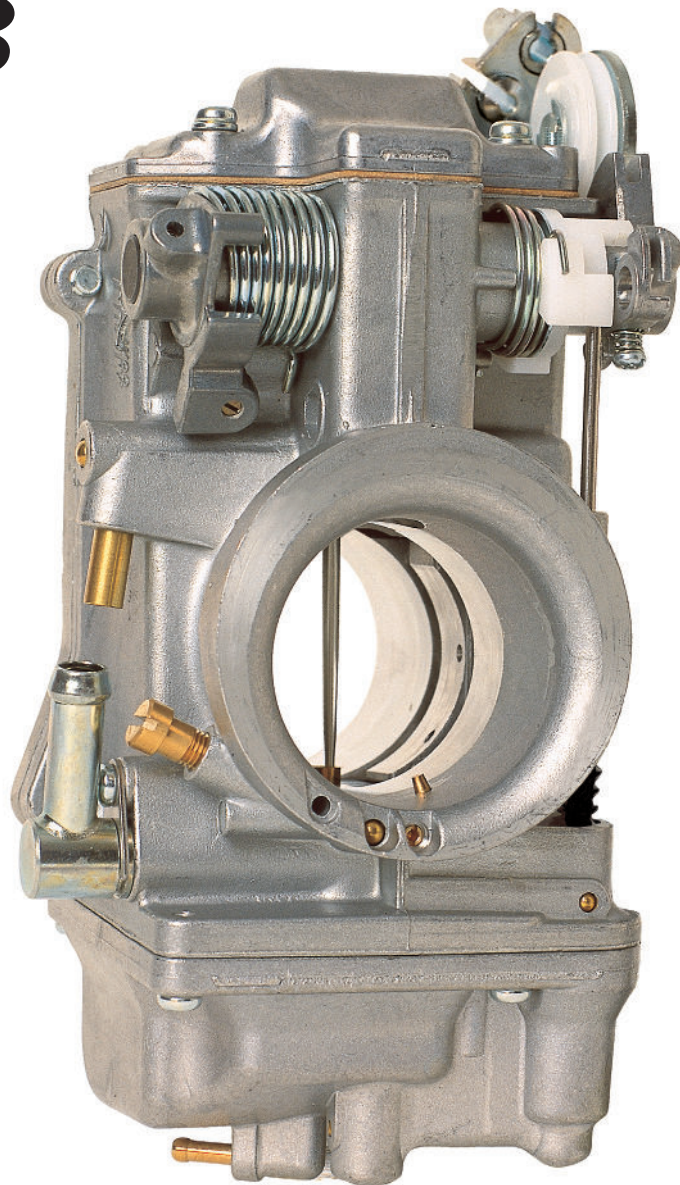

Bolt On a 25% Power and Torque Increase!

Mikuni's Easy Kit dramatically improves the performance of Harley-Davidson's Twin Cam engine and delivers unmatched throttle response and acceleration! Used with a Screamin' Eagle Air Filter and an aftermarket exhaust system like the optional Screamin' Eagle Mufflers, the HSR42 Easy Kit adds 25% more horsepower to the output of Harley's Twin Cam motor. Maximum horsepower is increased from 57.8 to 72.2 hp, and maximum torque from 71.4 to 80.7 ft/lbs.

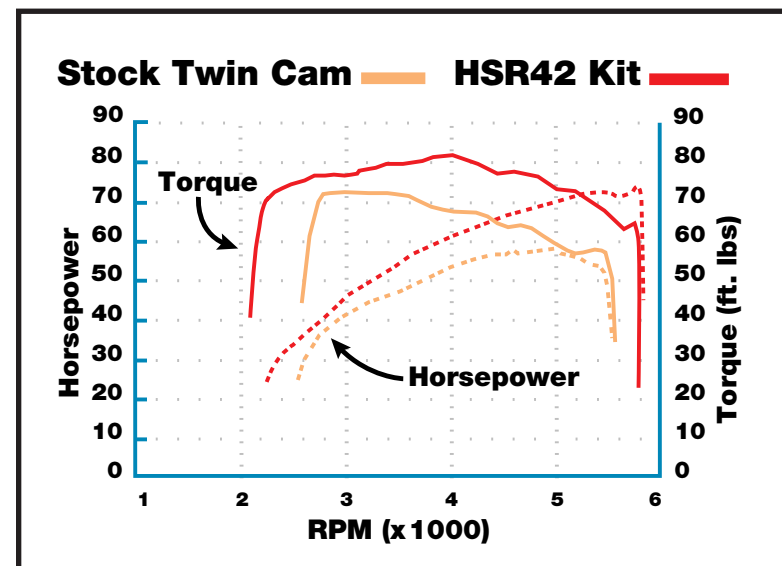

HSR Kits

42/45/48 Smoothbore Kits

Every Mikuni Carburetor Kit is an easy bolt-on application. Each HSR carburetor in the kit comes pre-jetted and ready to run!

◀ **Easy Kits 42/45mm** Keep your stock look with our uniquely designed Easy Kit which uses your stock manifold and cables. Our special adapter retains your stock airbox or use the Screamin' Eagle performance air filter kit. California A.R.B. Legal Kits available for EVO Big Twin applications.

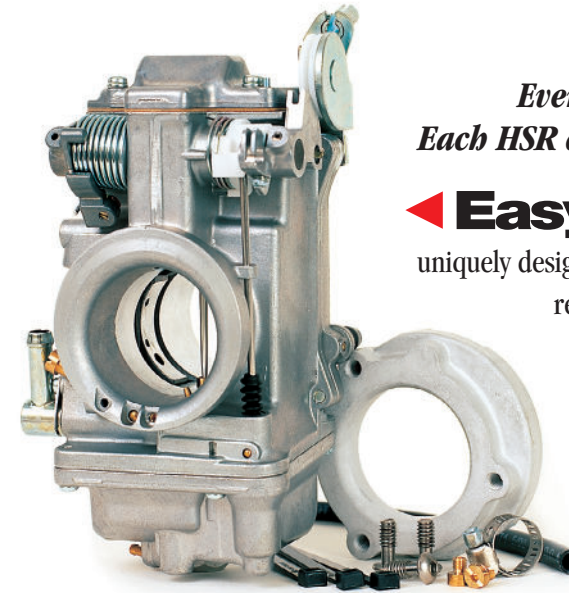

Race Kits 48mm A real racing carburetor for monster motors. The new HSR48 delivers the highest airflow with accurate fuel metering for more power and precise throttle control. An extended main jet and larger needle valve assembly assure maximum fuel flow to very powerful engines. Intended for use by experienced builders.

Total Kits ▶ 42/45mm

Go for high flow! The complete Total Kit includes a special manifold, rubber flange and high flow air filter. Total Kits allow fitment of a HSR42 or 45mm carburetor to any Big Twin Evolution or Twin Cam model. Our high flow filter supports 100 horsepower with no loss from filter restriction. (Manifold clamps, seals are not included in the kit).

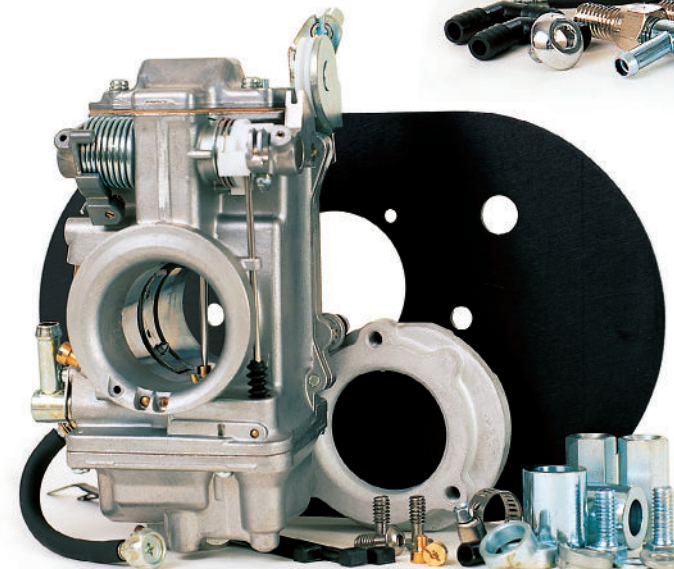
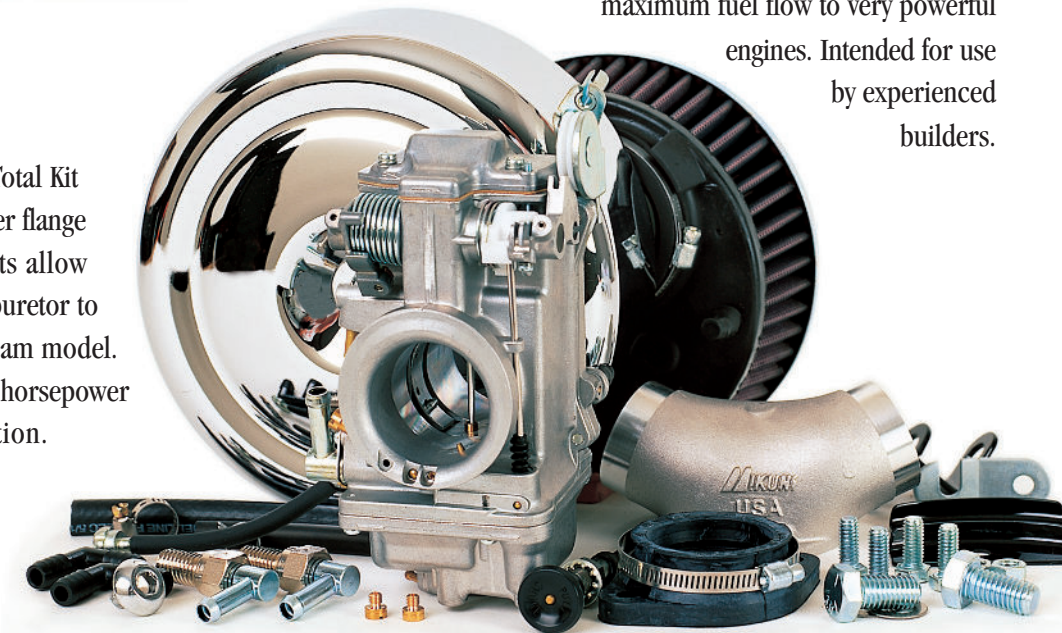

◀ Sportster / Buell Kits

Mikuni offers two different HSR42 Kits for Sportsters and Buells. One kit, just for Sportsters includes a special airbox backing plate as shown to work with the stock oval cover and a Screamin' Eagle high flow replacement filter. The other kit, without the backing plate, works on Buells and Sportsters with an aftermarket performance air filter assembly.

Carburetor kits not designated as C.A.R.B. exempt, are not legal for motor vehicles operated on public highways in the state of California or in other states and countries where similar anti-pollution laws may apply.

HSR Applications

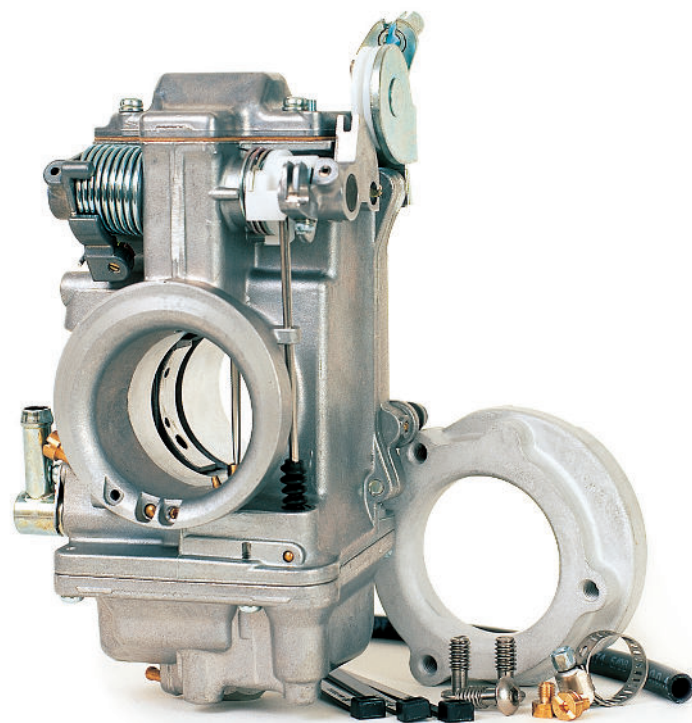

Total Kits for Big Twin Evolutions & Twin Cam models

These kits are complete with everything needed for a total installation. Kits include an HSR 42mm or 45mm carburetor, new performance manifold, rubber flange, high flow air filter, chrome cover, chrome breather kit and mounting hardware. *Stock throttle cables from 1990 and later models can be used. Note: 1984 to 1989 Evo models will need new cables from a similar 1990 to 1995 model.*

- 42-8 HSR42 Kits**
1984 to 1999 1340 Big Twin Evo.
Includes breather kit #KHS-020 for 1993 and later models. Note: 1984 to 1989 models require cables from 1990 to 1995 model bikes.
- 42-19** 1999 to present Twin Cam 88/95.
Includes new breather kit #KHS-030 for Twin Cams. Note: Use your stock throttle cables.
- 45-2 HSR45 Kits**
1984 to 1999 1340 Big Twin Evo.
Includes a 45 mm big bore carburetor, breather kit #KHS-020 and a 45mm flange.
- 45-3** 1984 to 1999 1340 Big Twin Evo.
Same as kit above without intake manifold.
- 45-4** 1999 to present Twin Cam 88/95.
Includes 45mm carb, breather kit #KHS-030, new manifold with MAPS location and 45mm flange.

Big Twin Evo CA Legal Kits

These kits may be used in California when all stock original components are unchanged. Kits are exempt from emission laws when installed according to instructions.

- 42-6** 1990 to 1998 1340 Big Twin Evolution models sold in California.
Includes 42mm C.A.R.B. carb, airbox adapter, A/C cover and instructions. C.A.R.B. exemption No. D-389-4.

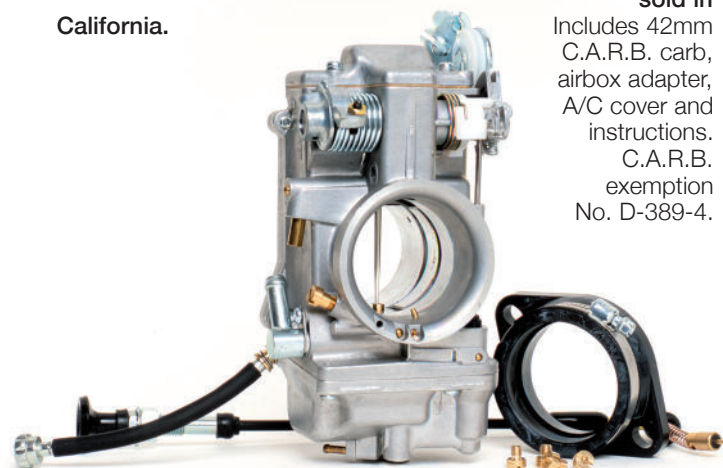

Race Kit 48mm for Big Motors

Designed for the serious race engine builder and extreme street motor enthusiast looking for more power. Recommended for 120ci engines or bigger with high flow heads and cams. Kits include a 48mm smoothbore carb, rubber mounting flange (78mm bolt hole centers), choke cable, four main jets. Builder supplies manifold and appropriate air filter or velocity stack. Uses stock Harley CV type cables.

- 48-2** HSR48 Race Kit, Standard
Standard cast alloy body, cadmium fittings
- 48-2P** HSR48 Race Kit, Polished
Hand polished cast alloy body, chrome fittings

Mikuni HSR Series Carburetor Kits

HSR Carbs use stock Harley-Davidson throttle cables.

The latest 42/45/48mm smoothbore carburetors from Mikuni install quickly using the original stock throttle cables. The HSR flatslide carb delivers excellent throttle response and control. The smoothbore allows the engine to reach its full power potential, so you accelerate and pass with confidence. You'll get good gas mileage and many years of dependable, carefree performance. These kits cover more models with fewer part numbers. Kits include instructions and hardware for each application.

Easy Kits for Sportsters, Big Twin and Twin Cam models

These kits are designed to work with your original Harley-Davidson intake manifold, choke cable, air cleaner and throttle cables. You can run other high performance air filters designed for the CV type carb by using the special adapter included in the kit.

- 42-7** 1990 to 1999 1340 Big Twin Evo with stock CV type manifold. Includes 42mm carb, airbox adapter and chrome cover.
- 42-18** 1999 to present Twin Cam, 1990 to '99 Big Twin Evo
Includes 42mm carb, air box adapter, instructions. Twin Cam and Evo engines require the use of an aftermarket air cleaner. Will not work with stock air box.
- 42-10** 1994 to 2004 Sportster 1200.
Includes 42mm carb, with special air box back plate. Requires the use of the stock oval cover and a Screamin' Eagle high flow replacement filter.
- 42-11** 1994 to 2006 Sportster 1200, Buell models.
Must use with aftermarket performance air filter.
- 45-5** 1999 to present Twin Cam, 1990 to '99 Big Twin Evo
Includes 45mm carb, air box adapter, instructions. Must use a H-D Screamin' Eagle Manifold Kit: Nos. 29634-00 (HTTC), 29635-99 (TC), or 29636-99 (Evo)

Parts

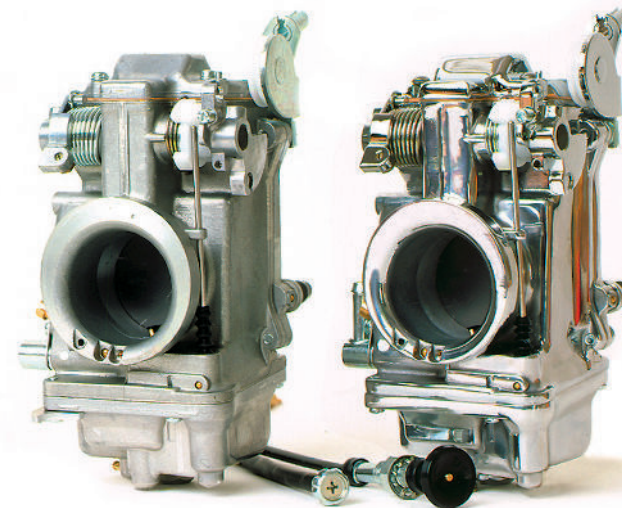

Individual HSR42/45 Carburetors

For the performance engine builder needing the carburetor only for specific custom applications. Available in standard aluminum finish or the polished version. (Note: Choke cable is included, except on TM42-6 which will use stock choke cable from CV type carb).

- TM42-6** HSR 42mm Carburetor, Standard finish
- TM42-6PK** HSR 42mm Carburetor, Polished version
- TM45-2K** HSR 45mm Carburetor, Standard finish
- TM45-2PK** HSR 45mm Carburetor, Polished version

HSR Accessories

Crankcase Head-Breather Kits

For the installation of HSR Carburetor Kits using the Mikuni K&N high flow filter on Big Twins and Twin Cams.

- KHS-020** To mount HSR42/45 carb and filter to Evo Big Twins, includes the new chrome banjos, vent bolts and brackets.
- KHS-030** To mount HSR42/45 carb and filter to Twin Cam engine, includes the new chrome banjos, vent bolts and brackets.

Jet Assortment Kit for HSR

Jet Assortment Kits contain 44 pieces in a special jet box. Included are 2 ea. of a wide range of Main Jets, Pilot Jets, Needles, A/P Nozzles, Needle Clips, Needle Washers.



- KHS-025** HSR42 Jet Kit with box, 44 piece assortment.
- KHS-045** HSR45 Jet Kit with box, 44 piece assortment.
- KHS-048** HSR48 Jet Kit with box, 44 piece assortment.

HSR42/45/48 Carb Rebuild Kits

All the necessary parts and gaskets to freshen up an HSR carb. Includes needle valve assembly, O-rings, gaskets, screws, and instructions. Shown at right:

- KHS-016** Rebuild Kit for HSR42/45 Carb with 4.2 needle valve
- KHS-017** Rebuild Kit for HSR42/45 Carb with 2.3 needle valve
- KHS-031** Rebuild Kit for HSR48 Carb with 4.5 needle valve

Optional and Replacement Parts

- 990-605-065** Short Idle Screw Adjuster (optional). Uses standard spring.
- TM42/32** Long Idle Cable Adjuster (standard). Spring not included.
- 990-662-002** Choke Cable, enrichener.
- HS42/001K** Air Box Adapter Kit, std. finish
- HS42/001-CHR-K** Air Box Adapter Kit, chrome finish
- HS42/002** Adapter Screws, use three per adapter.
- HS42/003** O-Ring Seal for airbox adapter.
- HS42/018-42K** Rubber Flange Adapter, early 42mm black w/stainless steel clamp.
- HS42/018-45K** Rubber Flange Adapter, early 45mm black w/stainless steel clamp.
- HS42/061-45** Intake Manifold for HSR42/45 mm, Evo style without hole.
- HS42/061-45TC** Intake Manifold for HSR42/45 mm, Twin Cam style with MAPS hole.
- HS42/062-42K** Rubber Flange Adapter, 42mm black w/stainless steel clamp.
- HS42/062-45K** Rubber Flange Adapter, 45mm black w/stainless steel clamp.
- HS42/062-48K** Rubber Flange Adapter, 48mm black w/stainless steel clamp.
- HS42/012** Air Filter Mikuni 2.5 inch standard in kits, washable
- HS42/012-300** Air Filter Mikuni 3.0 inch high performance, washable
- HS42/059** Air Cleaner Cover, chrome w/cutouts
- HS42/060** Air Cleaner Cover, chrome wo/cutouts
- KHS-028** Chrome Carb Top 42/45 wo/Mikuni
- KHS-029** Chrome Carb Top 42/45 w/Mikuni
- KHS-032** Chrome Carb Top 48 w/Mikuni logo

Jetting Parts

High speed (main), low speed (pilot) jets, jet needles and accelerator pump nozzle for the HSR42/45/48 carburetors.

- VM28/486**-(size) Pilot Jets, sizes 15 to 50
- N100.604**-(size) Main Jets, sizes 140 to 240
- J8-8DDY01**-(size) HSR42 Jet Needles, size 95, 96, 97 and 98, standard in HSR42 is 97.
- J8-8CFY02**-(size) HSR45 Jet Needles same as above
- J8-8CFY15**-(size) HSR48 Jet Needles same as above
- TM42/11**-(size) Accelerator Pump Nozzle, size 50, 60, and 70, standard is 70.
- N124.063** Accelerator Pump O-Ring



HSR42/45/48 Parts List

#	PART NO.	DESCRIPTION
1.	C5=0410-B	Screw, Top Cover (HSR42/45)
1a.	KHS-028/05	Screw, Top Cover (HSR48)
2.	CW2=0414-B	Screw, Top Cover (HSR42/45/48)
3.	776-39005	Top Cover (42/45)
3a.	HS42/081	Top Cover (HSR48)
4.	TM42/04	Gasket, Top Cover
5.	BS32/126	E-Ring, Jet Needle
6.	826-03002	Washer, Jet Needle
7.	J8-8DDY01-97	Jet Needle (42)
7a.	J8-8CFY02-97	Jet Needle (45)
7b.	J8-8CFY15-97	Jet Needle (48)
8.	TM42/03	Lever, T.V. (42/45)
8a.	TM42/08-1A	Lever, T.V. (HSR48)
9.	B401/56	E-Ring, Link Lever
10.	B401/10	Packing, Link Lever
11.	834-23041	Pin, Link Lever
12.	TM42/08-3.0	Throttle Valve (Slide)
13.	739-13002	Screw, Needle Retainer
14.	TM42/16	Clip, Needle Retainer
15.	TM42/13	Sealing Ring, T.V. (42/45)
15a.	TM48/04	Sealing Ring, T.V. (48)
16.	TM42/10	Seal, Throttle Valve
17.	925-98006	Pulley, Cable Bracket
18.	53974	E-Ring, Cable Bracket
19.	TM42/51	Bracket Assiy, Cable
19a.	TM42/53	Bracket Assiy, Sportster
20.	B3=0520-B	Bolt, Bracket
21.	VM28/204	Spacer, Bracket
22.	TM42/38	Plate, Lock Tab
23.	C2=0514-B	Screw
24.	640-12001	Starter Nut, Choke
25.	VM14/241	Spring, Starter Plunger
26.	N189.192	Starter Plunger
27.	TM42/06	Body (HSR42/45)
27a.	TM48/02	Body (HSR48)
28.	616-94029	Seal, Spigot Body
29.	925-19011	Ring (Steel)
30.	TM42/43	Lever, A/P
31.	N138.019	Pin, Throttle Lever
32.	TM42/48	Lever, Throttle
33.	M12F/46-BB	Spring, A/P
34.	MC-0316-B	Screw, A/P
35.	TM42/47	Spring, A/P
36.	TM42SS1/01-0	Mixing Body (42/45)
36a.	TM48SS1/01-0	Mixing Body (48)
37.	B36/95	Packing, Shaft (Plastic)
38.	TM42/36	Adjusting Screw, A/P
39.	B30/205	O-Ring, A/P Screw
40.	TM40/89	Bolt
40a.	TM42/17	Plate, Lock Tab for Shaft
41.	BN38/43	Pin, Return Lever
42.	TM42/46	Lever, Return
43.	B30/1069	Adjusting Screw, Throttle
44.	N3=04	Nut, Throttle Stop
45.	TM42/19	Spring, Throttle Return
46.	700-15012	Shaft, Throttle
47.	TM42/15	Plate, Fuel Joint Retainer
48.	C2=0410	Screw, Fuel Joint
49.	604-26014	Screw, Pilot Air
49a.	VM20/584	Optional Short Screw, Pilot Air
50.	N133.206	Spring, Pilot Air
51.	VM12/205	Washer, Pilot Air

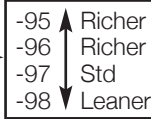

52.	N133.037	O-Ring, Pilot Air
53.	TM40/27	Fuel Joint
54.	KV/10	O-Ring, Fuel Joint
55.	B30/398	Packing, Idle Adjuster
56.	VM22/138	Washer, Idle Adjuster
57.	730-09018	Spring, Idle Adjuster
58.	925-15001	Ring, Idle Adjuster
59.	TM42/32	Idle Adjuster (Long)
59a.	990-605-065	Idle Adjuster (Short)
60.	BS30/97-00	Air Jet (Blank)
61.	784-430000-Y-6	Needle Jet (723)
62.	TM42/11-70	Nozzle, Accel. Pump
63.	N124.063	O-Ring, A/P
64.	VM28/486-25	Pilot Jet (Sportster - 20)
65.	TM42/12	Extender, Main Jet (42/45)
65a.	TM42/12-1A	Extender, Main Jet (48)
66.	N100.604-160	Main Jet (45-175, 48-190)
67.	616-33003	O-Ring N.V.
68.	VM13/216	Screw, N.V. Retainer
69.	786-27001-4.2	Needle Valve Assbly (42/45)
69a.	786-27002-1A-4.5	Needle Valve Assbly (48)
70.	859-32027	Float Assiy
71.	BV26/22	Pin, Float
72.	C2=0410	Screw, Float Pin
73.	616-94028	Packing, Float Bowl
74.	TM42/05	Float, Chamber Body
75.	N122.028	Hose, Overflow
76.	VM28/254	O-Ring, Drain Plug
77.	TM32/41	Drain plug (42/45)
77a.	TM32/41-1D	Drain plug (48)
78.	C2=0412-B	Screw, Flt Bowl, short
79.	TM36/44-1A	Rod, A/P
80.	TM36/64	Boot, A/P Rod
81.	TM36/60	Plunger, A/P
82.	VM14SC13/89	Spring, A/P
83.	N198.063	Rubber Cap, Purge Port
84.	990-662-002	Choke Cable
85.	TM29/31	Pull Choke Assembly
86.	BVK28/128	Clip, Rubber Cap

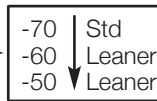

Alternate Parts

Jet Needles:

HSR42	HSR45	HSR48	
J8-8DDY01-95	J8-8CFY02-95	J8-8CFY15-95	Richer
J8-8DDY01-96	J8-8CFY02-96	J8-8CFY15-96	Richer
J8-8DDY01-97	J8-8CFY02-97	J8-8CFY15-97	Std
J8-8DDY01-98	J8-8CFY02-98	J8-8CFY15-98	Leaner

Accelerator Pump Nozzles:

TM42/11-70	Std
TM42/11-60	Leaner
TM42/11-50	Leaner

Needle Valve Assemblies:

786-27002-1A-4.5	Std (HSR48)
786-27001-4.2	Std (HSR42/45)
786-27001-3.5	Smaller
786-27001-2.3	Pressure feed only

Rebuild Kit:

HSR42/45:	KHS-016
HSR48:	KHS-031

NOTES:

1. Lined through Part Numbers are not available.
2. Parts in **Bold** are included in Rebuild Kits.

Exploded View HSR42/45/48

84 CHOKE CABLE ASSEMBLY
990-662-002

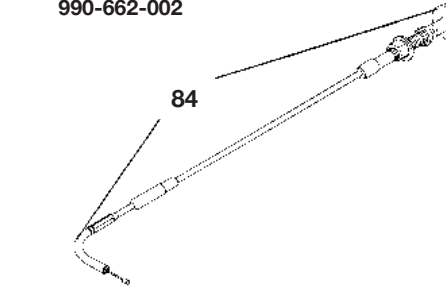

85 Choke Pull Assembly
TM29/31

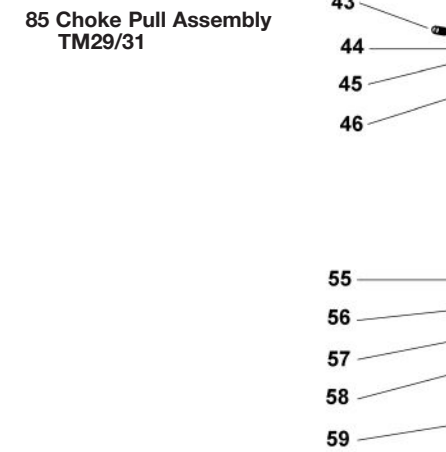

KHS-034 Main Jet Extender Kit
Includes a Threaded Extension Tube for lowering the Main Jet into a deeper Long Float Bowl Drain Plug (TM32/41-1C) to reduce fuel starvation under full throttle and high performance applications. See listing Page 9

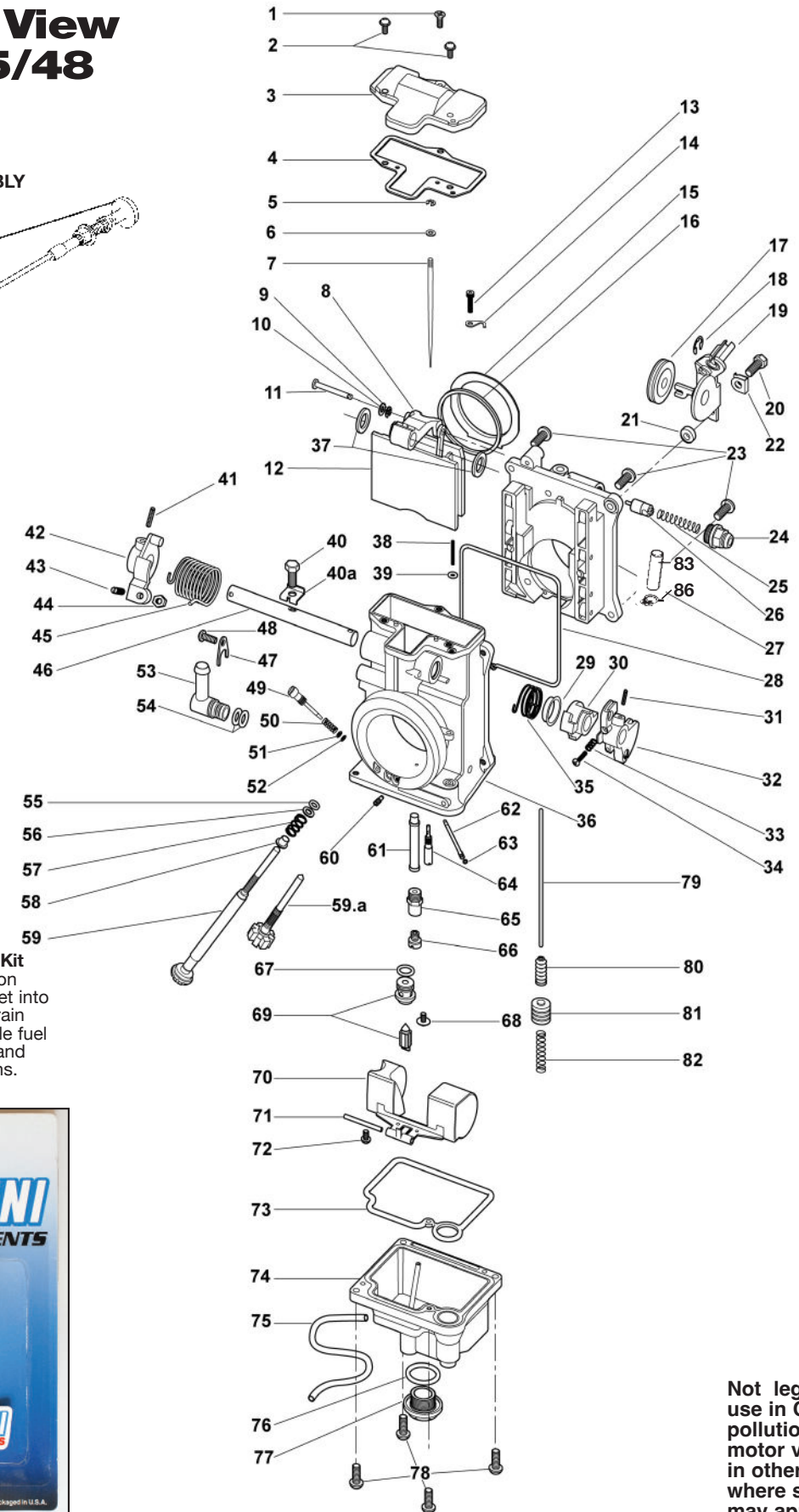

Not legal for sale or use in California on pollution controlled motor vehicles, or in other states where similar laws may apply.

HS40 Carburetor Exploded View same as TM40-6 and TM36-68

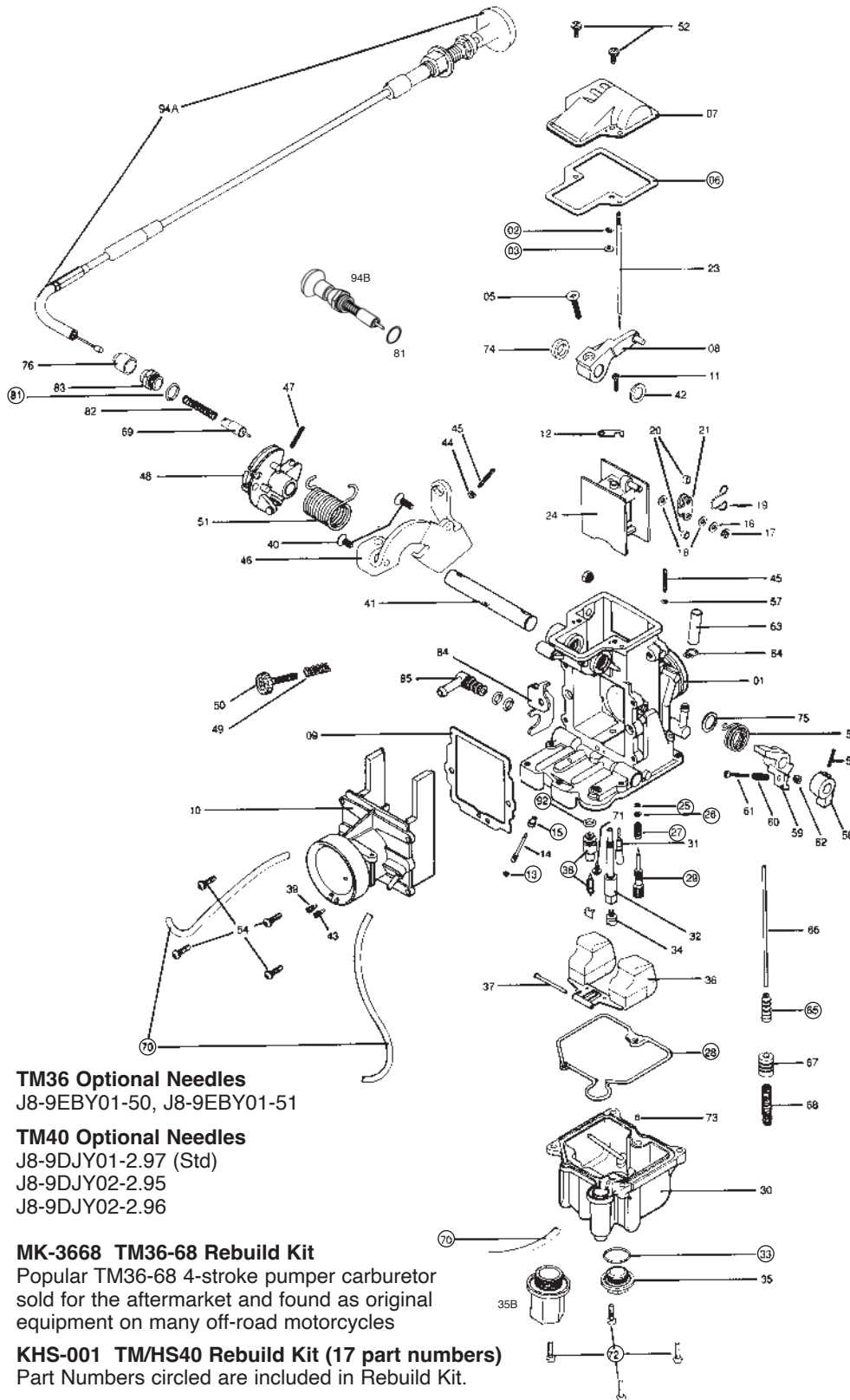

TM36 Optional Needles
J8-9EBY01-50, J8-9EBY01-51

TM40 Optional Needles
J8-9DJY01-2.97 (Std)
J8-9DJY02-2.95
J8-9DJY02-2.96

MK-3668 TM36-68 Rebuild Kit
Popular TM36-68 4-stroke pumper carburetor sold for the aftermarket and found as original equipment on many off-road motorcycles

KHS-001 TM/HS40 Rebuild Kit (17 part numbers)
Part Numbers circled are included in Rebuild Kit.

PART NUMBER (000-000) = NO AVAILABLE STOCK

NO.	DESCRIPTION	PART NO.	
01	Mixing body	FM4055/0+	
02	E. Ring	BS32/126	
03	Washer, Needle clip	826-03002	
04	Allen Screw	739-13001	
05	Screw, synch lock	C5 = 0514	
06	Gasket, top cover	TM 36/39	
07	Top Cover	TM-36/59	
08	Lever Assy	TM-36/57	
09	Gasket, funnel	TM-36/42a	
10	Funnel	TM-40/03	
11	Screw, T.V. Plate	C2 = 0310	
12	Plate, T.V. Lever	TM-36/42	
13	O'Ring, A/P Nozzle	N124.063	
14	Pump, Nozzle	TM 36/43	
15	Plug, A/P Nozzle	TM 29/14	
16	Washer, T. V. Lever	M-10/56	
17	E. Ring, A/P Nozzle	BSW-28/70	
18	Packing, T.V. Lever	D-401/40	
19	Clip T.V. Lever	TM-27/05-A	
20	Ring, T.V. Lever	TM-29/65	
21	Plate, T.V. Lever	TM-27/04	
22	Connector Plate, T.V.	TM 36/54	
23	Jet Needle	J8-9DJY01	9DZH6-50
24	Throttle, Valve	N/A	
25	O'Ring, Fuel Screw	N 133.037	
26	Washer, Fuel Screw	VM 12/33	
27	Spring, Fuel Screw	N 133.206	
28	O'Ring Float Bowl	616-94021	
29	Screw, Pilot Fuel	604-26003	
30	Float Chamber Body	TM 40/12	
31	Pilot Jet	VM 28/486-17.5	-12.5
32	Needle Jet	784-13002-Y6	-P-8
33	O'Ring Drain Plug	VM 28/254	
34	Main Jet	N 100.604-165	-130
35	Drain Plug	TM 32/41	
35B	Drain Plug, Long (36)	TM32/41-1C	
36	Float Assy	859-32011	
37	Pin, Float	VM 30/160	
38	Needle Valve Assy (36)	786-36011-3.3	
38A	Needle Valve Assy (40)	990-786-044	
39	Main Air Jet (Plugged)	BS30/97	
40	Screw, Crank Bracket	C5 = 0512-B	
41	Shaft, Throttle	700-15004	
42	Packing		
43	Pilot Air Jet	BS 30/97-1.1	-1.0
44	Hexagon Nut	N2 = 03 B	
45	Adjust Screw	TM 36/48	
46	Bracket, Bell Crank	TM 40/14	
47	Pin, Throttle Bell Crank	N 138.019	
48	Lever Assy, Bell Crank	TM 40/23	
49	Spring, Idle Adjust	N150.025	
50	Adjuster, Idle	TM 40/91	
51	Spring, Throttle Return	TM-40/25	
52	Screw, Top Cover	CW2 = 0408	
54	Screw, Air Funnel	VM-38/433	
55	Pin, A/P Locate	BN 38/43	
56	Lever, A/Pump	TM 36/18	
57	O'Ring	B 30/205	
58	Spring, A/Pump	TM-40/33	
59	Lever, A/Pump	TM 36/17	
60	Spring, A/P Adj	M12F/46a	
61	Screw, A/P Adj	MC-0316	
62	Hexagon nut, A/P Adj	N3 = 03-B	
63	CAP, Vacuum Fitting	N148.013	
64	Spring Clip, Vac Fit	BVK28/128	
65	CAP, A/P Rubber	TM 36/64	
66	Rod, A/Pump	TM 36/44	
67	Plunger	TM 36/60	
68	Spring, A/Pump	VM 14SC13/89	
69	Plunger, Starter	VM 38/148	
70	Hose	888-23026	
71	Screw, N.V. Holder	VM 13/216	
72	Screw, Float Bowl	C2 = 0412-B	
73	Starter Jet	VM 17/1002-45	
74	Packing, Shaft	VM-28/474	
75	Ring, A/P Spring	E-204040	
76	Cap, Starter Cable	VM 12/43	
81	O'Ring, Starter	N 138.198	
82	Spring Starter	VM 16/42	
83	Guide Holder	640-12001	
84	Plate, Fuel Inlet	TM-40/26	
85	Inlet, Fuel	TM 40/27	
92	O'Ring, needle valve	KV/10	
94	Choke Cable Assy	990-662-001	
94B	Chokeknob, Short	TM40/07	

TM36 Jetting

Mikuni HSR and TM Carburetor Parts and Accessories

The following Mikuni American Accessories are available for use with Mikuni HS40, HSR42/45/48 Carburetor Kits. These parts are available through your Mikuni Dealer.

ACCESSORIES

	Part Nos. HS40	HSR42/45/48
Carburetor Rebuild Kit (Includes gaskets & needle valve)	KHS-001	KHS-016, KHS-031 (48)
HSR Easy Tool Kit (Includes Wrench, T-Handle, 2 Bits)		KHS-033
Mikuni Air Filter - Standard 2.5 / High Flow		HS 42/012 (2.5')
Mikuni Air Filter - Extra Wide 3.0 / High Flow		HS 42/012-300 (3.0')
Chrome Air Cleaner Cover (OEM / cut-outs)		HS42/059
Chrome Air Cleaner Cover (Aftermarket / No cut-outs)	RS36/24-200-CHR	HS42/060
EVO Head Breather Kit (1991 to present Sportsters / 1993 to present 1340's)		KHS-020
Twin Cam Head Breather Kit		KHS-030
EVO 1340 Manifold		HS42/061-45
Twin Cam Manifold		HS42/061-45TC
Rubber Flange, Early Style (with clamp)	KHS-004	HS42/018-42K HS42/018-45K
Rubber Flange, New Style (with clamp)	KHS-004	HS42/062-42K HS42/062-45K HS42/062-48K
Choke Cable Assembly	990-662-001	990-662-002
Choke Pull Assembly		TM29/31
Optional Short Idle Screw		990-605-065
HSR Main Jet Extension Kit for high performance applications (shown on page 7)		KHS-034



HSR Easy Tool Kit KHS-033 Includes:
Wrench 17mm x 11/16' loosen/tighten choke nut,
drain plug. Main Jet T-Wrench, Phillips/Flat Head
Screwdriver, Ball End 2.5 Allen for jet needle retainer.

EARLY GEN 1 HSR Carburetor Designs

**Early Style
HSR42/45**
Manufactured
before year 2000
with throttle linkage
on left. Uses Mikuni
throttle cables.

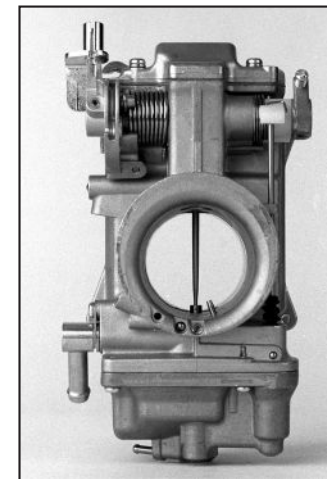

LATER GEN 2 HSR Carburetor Designs

**Late Style
HSR42/45/48**
Manufactured from
year 2000 with
throttle linkage on
right. Uses stock
OEM Harley-Davidson
throttle cables.

